



UNLEASHING
POWER

UNLOCKING
VALUE



Series J
Shaft Mounted Speed Reducers

GEARED MOTORS • GEARBOXES • GEAR ASSEMBLIES • DRIVE SOLUTIONS

General Description _____	3
Unit Designations _____	4
Selection Procedure _____	5 - 6
Power ratings / Thermal power ratings	
1-stage [J11 to J100] _____	7
2-stage 15:1 [J12 to J72] _____	8
2-stage 25:1 [J12 to J72] _____	9
2-stage 15:1, 20:1 and 25:1 [J100] _____	10
Dimensions	
J 11 - 71 1-stage _____	11 - 12
J 100 - 1-stage _____	13 - 14
J 12 - 72 - 2-stage _____	15 - 16
J 100 - 2-stage _____	17 - 18
Selection of V-belt drives	
Power ratings V-belt transmissions _____	19 - 43
Accessories	
Threaded holes at gear house sides _____	44
Shaft bushings _____	45
Machine shaft dimensions _____	46 - 48
KIBO Tapered bushing _____	49 - 50
Motor mounts _____	51 - 52
Shrink disc, Protection cover, V-belt protection cover _____	53
Backstop	
Backstop mounting _____	54 - 55
Installation and Maintenance	
Mounting Instructions _____	56
Lubrication instructions _____	57

GENERAL DESCRIPTION

Series J

Series J Shaft Mounted Speed Reducers are high quality products, submitted to intense quality control and manufactured with the highest precision.

- Worldwide after sales service
- 6 Size up to 161 kW, 10,000 Nm
- Wide range of standard accessories
- High efficiency
- Long gear and bearing lifetime
- All mounting positions possible
- Easy to mount
- Easy to change speed through change of V-belt transmission
- Space saving
- Low noise level
- Easy to service, due to standard components

The shaft sleeve is supplied with tapped holes for dismantling the reducer as well as locking the reducer to the shaft.*

The input shaft diameter corresponds to IEC standard for motor shafts, thus simplifying standardization of V-belt pulleys and couplings. Locating shoulder provided for pulleys and couplings.

The input shaft is supplied with tapped hole for fitting V-belt pulley or locking washer for V-belt pulley.

All housing contact surfaces are fine milled thus eliminating the necessity for gaskets and possible oil leaks.

KIBO® - One of the most cost efficient dismantling methods that is available on the market is patented by Benzlers (Group company of ELECON) and available as a standard accessory to every Series J shaft mounted speed reducer.

Modern heat treatment of high quality gives gear wheel and pinions the hard wearing surface and tough core necessary to handle harsh duties.

Manufacturing tolerances comply to DIN and AGMA specifications. Helix angle and small modules give more teeth in mesh for smooth and quiet running.

High quality bearings selected for long service life.

Backstop options are available for all double reduction units (For single stage units on special request).

High quality close grained cast iron housing with maximum rigidity and low weight saves space.

Torque arm bracket will stand up to tough reversible shock load applications allowing for two torque arms to be mounted in opposite directions.

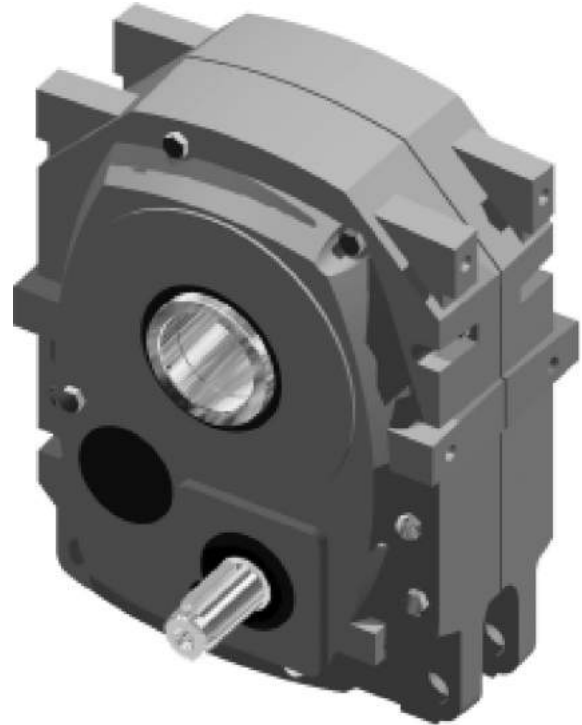

* Not standard for the smallest sizes of single and double reducers.

UNIT DESIGNATIONS

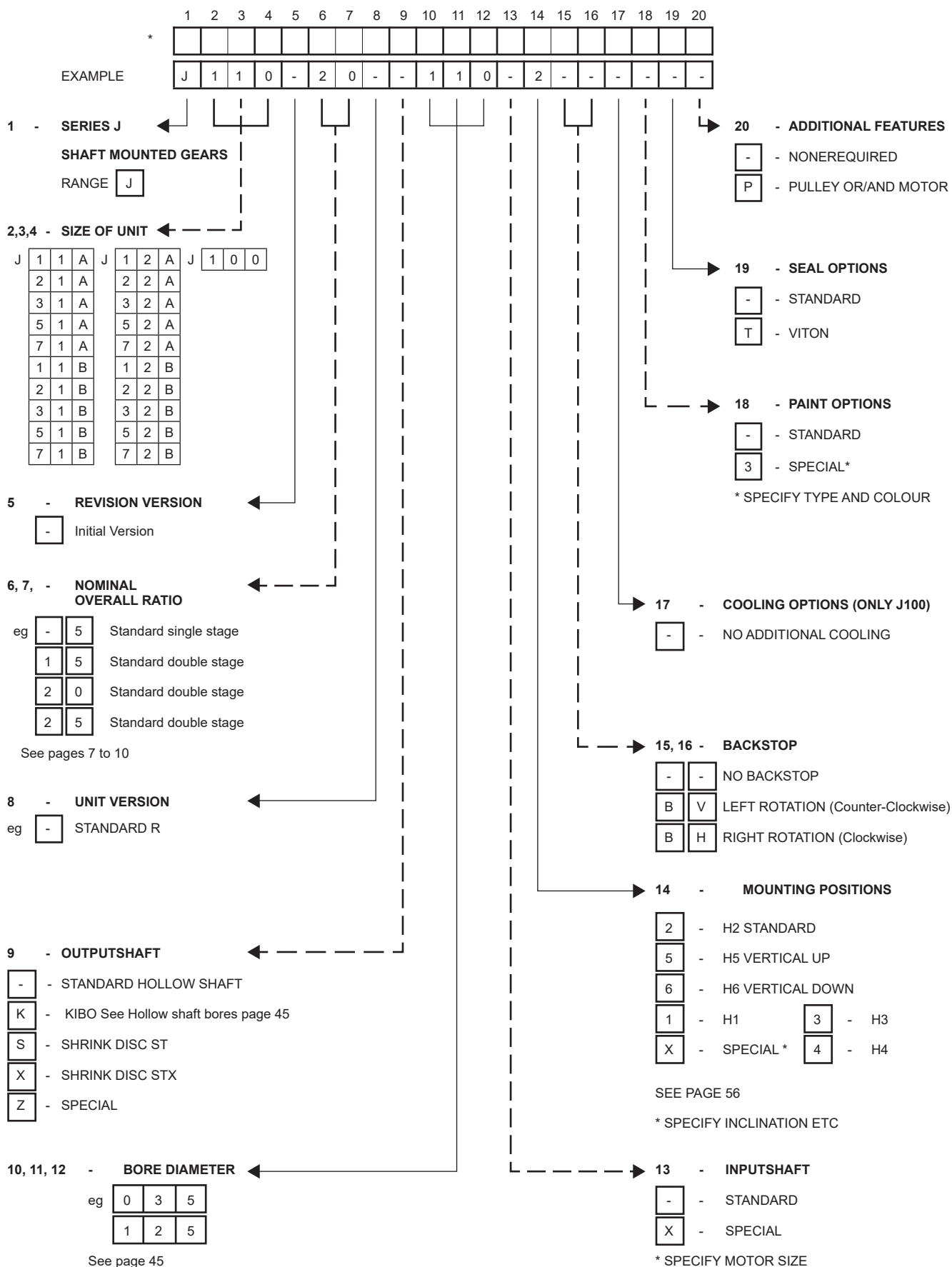

*THIS PAGE MAY BE PHOTOCOPIED ALLOWING THE CUSTOMER TO ENTER THEIR ORDER

SELECTION PROCEDURE

Definition of service factor

The torque ratings apply to service factor $f_b = 1.0$. The service factor $f_b = 1.0$ gives continual operation 4 to 8 hours a day at a uniform load without shocks and with 10 to 200 starts an hour. The moment of inertia of the driven machines is less than 20 % of the electric motor inertia and occasional peak torque may not exceed 1.8 times the torque rating. For other running conditions compensate with service factors according to tables.

Definitions

- P_e = Demand of power from driven machine (kW)
 T_e = Demand of torque from driven machine (Nm)
 n_e = Speed on driven machine (min⁻¹)
 T_{emax} = Max peak torque from driven machine (Nm)
 T_2 = Max allowed torque at service factor $f_b = 1,0$

Thermal rating

Thermal rating is the power in kW (without service factor) that the gear unit can transmit at continuous operation in 1 hour or more without getting overheated.

Control of thermal rating is essential because if the service generates more heat than it can emit, severe damage may occur.

Thermal rating does not need to be controlled if the duty time is less than 1 hour.

When the duty time is longer than 1 hour the gear unit and cooling method must be selected so that the drive transmission has enough thermal rating.

In the tables the thermal rating P_t is given in the following conditions:

- 25 °C ambient temperature
- 0 to 750 m altitude above sea level
- Ambient air velocity between 1.4 and 3.7 m/s (sheltered outdoor space)
- Continuous operation

For sizes J100 standardized solutions for cooling of the gears are available. An electric fan can be mounted on the gear. The gear may also be provided with a water-based oil cooler (contact our Application Engineers for selection of correct size).

- 1) At V-belt drive when the motor is placed beside the gear, check the operation according to the diagram.

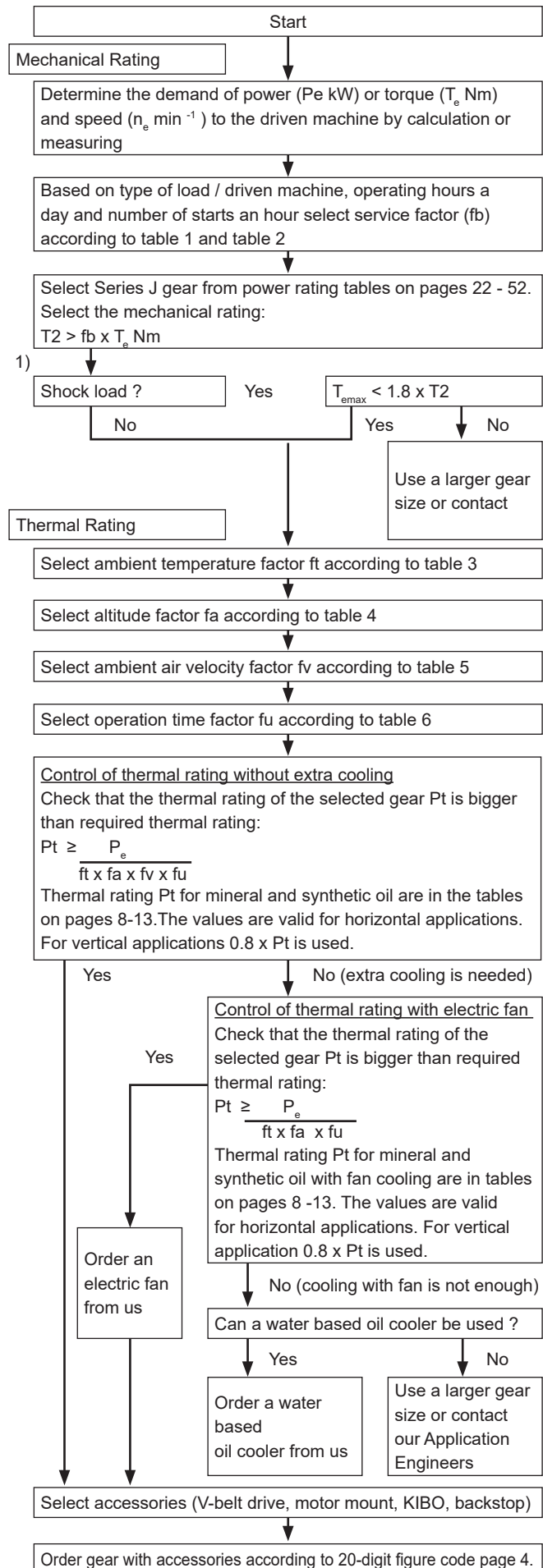

SELECTION PROCEDURE

Service factors

Table 1. Service factor fb

Daily operation		4 hours			8 hours			16 hours			24 hours		
Starts per hour		<10	10-200	>200	<10	10-200	>200	<10	10-200	>200	<10	10-200	>200
Load classification	U	0.8	0.9	1.0	0.9	1.0	1.1	1.1	1.2	1.3	1.3	1.4	1.5
	Ua	1.1	1.2	1.3	1.1	1.3	1.5	1.3	1.5	1.6	1.4	1.6	1.8
	M	1.3	1.4	1.6	1.3	1.6	1.8	1.4	1.7	1.9	1.5	1.8	2.0
	H	1.5	1.6	1.8	1.6	1.8	2.0	1.7	1.9	2.1	1.8	2.0	2.2

Table 2. Description of load classifications

Load classifications	Description Mass acceleration factor	Example
Uniform U	Machines with uniform load and no shocks Mass acceleration factor < 0.2	Uniform loaded conveyors and elevators. Centrifugal pumps and fans. Agitators and mixers for liquids and semi-liquids without solid particles.
Uniform Ua	Machines with small shocks and small variations in load Mass acceleration factor < 1	Medium sized conveyors. Displacement pumps. Agitators and Machines with small shocks and small variations in mixers for media with moderate viscosity and/or small content load of solid particles.
Moderate M	Machines with moderate shocks and variable load Mass acceleration factor < 3	Larger conveyors. Reciprocating pumps with 3 or more cylinders. Agitators and mixers for media with high viscosity and / or solid particles
Heavy H	Machines with very heavy shocks and large masses to be accelerated Mass acceleration factor < 10	Heavy agitators and mixers. Reciprocating pumps with 1 or 2 cylinders. Crushers, mills and presses. Vibrators and shakers

Mass acceleration factor = $\frac{\text{all external moments of inertia}^*}{\text{moment of inertia of driving motor}}$ * calculated with reference to the motor speed

Table 3. Ambient temperature factor ft (All cooling methods)

Ambient temperature °C	Factor ft
10°C	1.17
15°C	1.12
20°C	1.06
25°C	1.00
30°C	0.94
35°C	0.88
40°C	0.81
45°C	0.74
50°C	0.66

Table 4. Altitude factor fa (Only for air cooling)

Altitude m	Factor fa
0 - sea level	1.00
750	0.95
1500	0.90
2250	0.85

Table 5. Ambient air velocity factor fv (Without electric fan)

Air velocity V ref m/s	Environment	Factor fv
Vref < 0.5	Small confined space	0.53
0.5 < Vref < 1.4	Large indoor space	0.71
1.4 < Vref < 3.7	Sheltered outdoor space	1.00
Vref > 3.7	Outdoor space	1.35

Table 6. Operation time factor fu (All cooling methods)

Operation	Factor fu
100%	1.00
80%	1.05
60%	1.15
40%	1.35
20%	1.80

SERIES J

POWER RATINGS - SINGLE REDUCTION

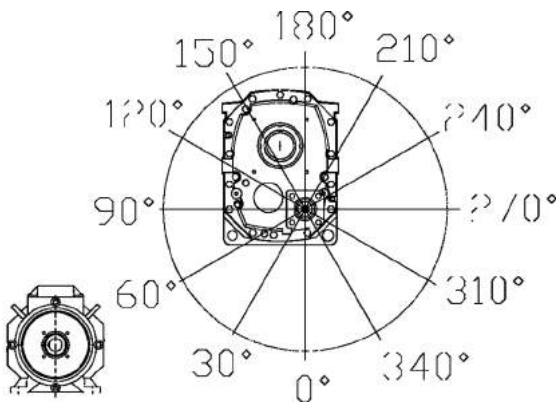

Rpm	J100
0 - 60	1
60 - 80	1
80 - 100	1
100 - 200	1

Specification of factor for V-belt forces in different angles. Power ratings have to be multiplied with this factor for sizes J100 when motor is located in angle 90 - 210°.

Fig.1

Single reduction The torque is shown in Nm (1 Nm = 0.102 kpm = 0.7376 lbf.ft)

Output rpm	J11 4.94:1		J21 5.00:1		J31 5.00:1		J51 5.08:1		J71 4.94:1	
	for driven pulley Pitch ø140		for driven pulley Pitch ø160		for driven pulley Pitch ø180		for driven pulley Pitch ø355		for driven pulley Pitch ø355	
	kW	Nm	kW	Nm	kW	Nm	kW	Nm	kW	Nm
80	2.57	307	8.93	1066	8.44	1007	16.89	2016	22.84	2726
100	2.98	285	10.44	997	9.79	935	19.59	1871	26.5	2531
120	3.37	268	11.86	944	11.06	880	22.13	1761	29.92	2381
140	3.74	255	13.21	901	12.26	836	24.53	1673	33.16	2262
160	4.09	244	14.51	866	13.39	799	26.81	1600	36.26	2164
180	4.41	234	15.76	836	14.48	768	28.99	1538	39.2	2080
220	5.05	219	18.13	787	16.56	719	33.15	1439	44.83	1946
260	5.64	207	20.39	749	18.51	680	37.05	1361	50.09	1840
300	6.22	198	22.52	717	20.36	648	40.74	1297	55.13	1755
350	6.89	188	25.1	685	22.58	616	45.15	1232	61.09	1667
400	7.5	179	27.56	658	24.67	589	49.38	1179	66.76	1594
450	8.1	172	29.92	635	26.67	566	53.39	1133	72.24	1533
500	8.74	167	32.2	615	28.59	546	57.28	1094	77.49	1480
Thermal rating Pt in kW at 25° C ambient temperature, outdoor and 24 hours daily working.										
	13		17		23		25		31	

Output rpm	J100 5.07:1	
	for driven pulley Pitch ø250	
	kW	Nm
80	44.88	5358
100	52.47	5011
120	59.61	4744
140	66.41	4530
160	72.91	4352
180	79.18	4201
220	91.11	3955
260	102.42	3762
300	113.21	3604
350	126.11	3441
400	138.47	3306
450	150.36	3191
500	161.88	3092

Thermal rating Pt kW at 25 C ambient temperature outdoor at continuous operation

			J100
<150	rpm	Mineral	72
		Synthetic	131
		Mineral with fan	144
		Synthetic with fan	183
151 - 300	rpm	Mineral	77
		Synthetic	125
		Mineral with fan	162
		Synthetic with fan	210
>300	rpm	Contact Benzlers	

**When the reducer is working with a low output speed less than:
For single reduction 1 RPM
For double reduction 0.3 RPM
Please contact Application Team**

SERIES J

POWER RATINGS - DOUBLE REDUCTION 15:1

Double reduction The torque is shown in Nm (1 Nm = 0.102 kpm = 0.7376 lbf.ft)

Output rpm	J12 15.09:1		J22 15.22:1		J32 15.45:1		J52 15.39:1		J72 14.61:1	
	for driven pulley Pitch ø140		for driven pulley Pitch ø160		for driven pulley Pitch ø180		for driven pulley Pitch ø200		for driven pulley Pitch ø280	
	kW	Nm	kW	Nm	kW	Nm	kW	Nm	kW	Nm
6	0.5	800	.94	1500	1.38	2200	1.82	2900	3.14	5000
8	0.67	800	1.26	1500	1.84	2200	2.43	2900	4.19	5000
10	0.84	800	1.57	1500	2.3	2200	3.03	2898	5.24	5000
12	1.01	800	1.88	1500	2.76	2196	3.64	2893	6.28	4995
14	1.17	800	2.2	1500	3.21	2193	4.23	2888	7.31	4987
16	1.34	800	2.51	1500	3.67	2190	4.83	2884	8.34	4979
18	1.51	800	2.82	1498	4.12	2187	5.43	2880	9.37	4971
20	1.68	800	3.13	1496	4.57	2184	6.02	2876	10.4	4964
22	1.84	800	3.44	1495	5.03	2182	6.62	2872	11.42	4958
24	2.01	800	3.75	1493	5.48	2180	7.21	2869	12.44	4951
26	2.18	800	4.06	1492	5.93	2177	7.8	2865	13.46	4945
28	2.35	800	4.37	1490	6.26	2135	8.39	2862	14.48	4939
30	2.51	800	4.68	1489	6.57	2091	8.98	2859	15.5	4934
35	2.93	800	5.45	1486	7.32	1996	10.45	2852	18.04	4921
40	3.35	800	6.21	1483	8.03	1918	11.92	2845	20.56	4909
45	3.77	800	6.97	1480	8.72	1851	13.38	2839	22.61	4798
50	4.18	799	7.74	1478	9.39	1794	14.83	2833	24.34	4649
55	4.6	798	8.43	1463	10.04	1743	16.29	2828	26.02	4518
60	5.0	796	8.95	1425	10.67	1698	17.74	2823	27.66	4402
65	5.41	795	9.47	1391	11.28	1658	19.18	2818	29.25	4297
70	5.82	794	9.98	1361	11.89	1622	20.62	2813	30.81	4203
80	6.63	792	10.95	1307	13.05	1558	23.49	2804	33.83	4038
90	7.41	786	11.89	1262	14.17	1504	26.34	2795	36.73	3897
100	7.86	751	12.81	1223	15.26	1457	29.18	2787	39.54	3776
110	8.37	727	13.68	1188	16.31	1416	32.02	2780	42.27	3670
120	8.78	699	14.55	1158	17.33	1379	34.83	2772	44.92	3575
140	9.73	664	16.2	1105	19.31	1317	39.86	2719	50.03	3413
Thermal rating Pt in kW at 25° C ambient temperature, outdoor and 24 hours daily working.										
Pt kW	10		15		21		27		33	

SERIES J

POWER RATINGS - DOUBLE REDUCTION 25:1

Double reduction The torque is shown in Nm (1 Nm = 0.102 kpm = 0.7376 lbf.ft)

Output rpm	J12 24.94:1		J22 24.38:1		J32 24.17:1		J52 24.72:1		J72 24.44:1	
	for driven pulley Pitch ø140		for driven pulley Pitch ø160		for driven pulley Pitch ø180		for driven pulley Pitch ø355		for driven pulley Pitch ø355	
	kW	Nm	kW	Nm	kW	Nm	kW	Nm	kW	Nm
6	.5	800	.94	1500	1.38	2200	1.82	2900	3.14	5000
8	.67	800	1.26	1500	1.84	2200	2.43	2900	4.19	5000
10	.84	800	1.57	1500	2.3	2200	3.03	2898	5.24	5000
12	1.01	800	1.88	1500	2.76	2196	3.64	2893	6.28	4995
14	1.17	800	2.2	1500	3.21	2193	4.23	2888	7.31	4987
16	1.34	800	2.51	1500	3.67	2190	4.83	2884	8.34	4979
18	1.51	800	2.82	1498	4.12	2187	5.43	2880	9.37	4971
20	1.68	800	3.13	1496	4.51	2155	6.02	2876	10.4	4964
22	1.84	800	3.36	1460	4.82	2094	6.62	2872	11.42	4958
24	2.01	800	3.58	1423	5.13	2040	7.21	2869	12.44	4951
26	2.18	800	3.78	1389	5.42	1992	7.8	2865	13.46	4945
28	2.35	800	3.98	1358	5.71	1948	8.39	2862	14.48	4939
30	2.51	800	4.18	1331	5.99	1908	8.98	2859	15.5	4934
35	2.93	800	4.65	1270	6.68	1822	10.45	2852	18.04	4921
40	3.35	800	5.11	1221	7.33	1750	11.92	2845	20.56	4909
45	3.77	800	5.55	1178	7.96	1689	13.38	2839	23.07	4897
50	4.18	799	5.97	1141	8.57	1637	14.47	2763	24.85	4746
55	4.6	798	6.39	1109	9.16	1591	15.41	2676	26.57	4613
60	5	796	6.79	1081	9.74	1550	16.34	2600	28.23	4494
65	5.28	776	7.18	1055	10.3	1513	17.23	2531	29.86	4387
70	5.56	758	7.56	1032	10.85	1480	18.1	2470	31.45	4291
80	6.01	717	8.3	991	11.91	1422	19.79	2362	34.53	4122
90	6.49	689	9.02	957	12.93	1372	21.4	2271	37.5	3979
100	6.88	657	9.71	927	13.92	1329	22.96	2193	40.37	3855
110	7.34	637	10.38	901	14.88	1292	24.46	2124	43.16	3747
120	7.77	618	11.03	878	15.82	1259	25.92	2063	45.86	3650
140	8.5	580	12.28	838	17.59	1200	28.73	1960	51.09	3485
Thermal rating Pt in kW at 25° C ambient temperature, outdoor and 24 hours daily working.										
Pt kW	10		15		21		27		33	

SERIES J

POWER RATINGS - DOUBLE REDUCTION 15:1, 20:1 AND 25:1

Double reduction The torque is shown in Nm (1 Nm = 0.102 kpm = 0.7376 lbf.ft)

Output rpm	J100 15.94:1		J100 19.99:1		J100 25.00:1	
	for driven pulley Pitch ø250		for driven pulley Pitch ø250		for driven pulley Pitch ø250	
	kW	Nm	kW	Nm	kW	Nm
6	6.28	10000	6.28	10000	6.28	10000
8	8.38	10000	8.38	10000	8.38	10000
10	10.47	10000	10.47	10000	10.47	10000
12	12.57	10000	12.57	10000	12.57	10000
14	14.66	10000	14.66	10000	14.66	10000
16	16.75	10000	16.75	10000	16.75	10000
18	18.85	10000	18.85	10000	18.85	10000
20	20.94	10000	20.94	10000	20.94	10000
22	23	9986	23.04	10000	23.04	10000
24	25.06	9973	25.13	9999	25.13	9999
26	27.11	9959	27.19	9986	27.19	9986
28	29.16	9947	29.24	9974	29.24	9974
30	31.21	9935	31.29	9962	31.29	9962
35	36.3	9906	36.41	9934	36.41	9934
40	41.38	9880	41.5	9909	41.5	9909
45	46.44	9855	46.58	9885	46.58	9885
50	51.48	9832	51.63	9862	51.63	9862
55	56.5	9810	56.68	9841	56.68	9841
60	61.5	9789	61.7	9820	61.7	9820
65	66.49	9769	66.71	9801	66.71	9801
70	71.47	9750	70.83	9663	70.83	9663
80	79.86	9533	77.76	9283	77.76	9283
90	86.72	9202	84.45	8961	84.45	8961
100	93.36	8916	90.91	8682	90.91	8682
110	99.81	8665	97.18	8437	97.18	8437
120	106.06	8441	103.29	8220	103.29	8220
140	118.16	8060	115.05	7848	115.05	7848

Thermal rating Pt in kW at 25° C ambient temperature, outdoor and 24 hours daily working.

Output speed rpm	J100 15.94:1 2-stage				J100 19.99:1 2-stage				J100 25.00:1 2-stage			
	no fan		electric fan		no fan		electric fan		no fan		electric fan	
	mineral kw	synthetic kw	mineral kw	synthetic kw	mineral kw	synthetic kw	mineral kw	synthetic kw	mineral kw	synthetic kw	mineral kw	synthetic kw
2 - 50	42	64	69	126	42	64	69	126	42	64	69	126
51 - 80	52	72	71	147	52	72	71	147	52	72	71	147
81 - 100	49	67	77	163	49	67	77	163	49	67	77	163
> 101	Contact your local PBPL sales office.											

SERIES J

DIMENSIONS - SINGLE REDUCTION

J11 - 71 Single Reduction

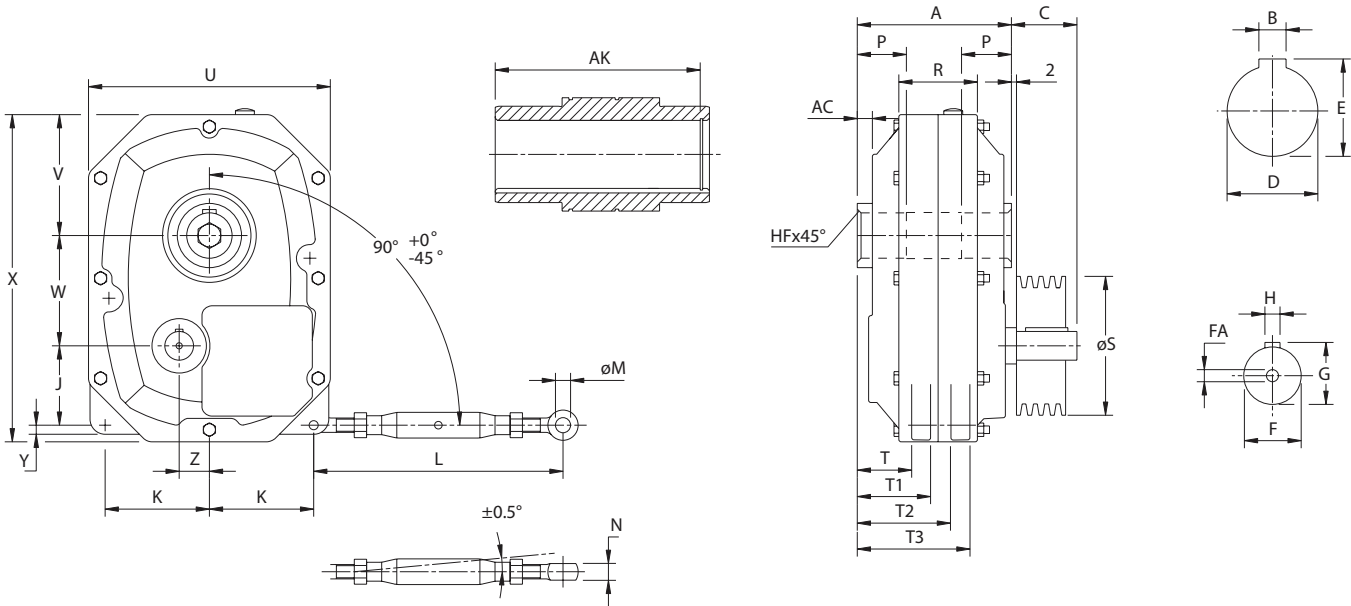

Please note: Dimensions R, T, T1, T2, T3 are not machined, deviations can occur.

Size	Ratio	A	AC	C ¹	J	K	L		M	N	P	R	T	T1	T2	T3	S ²	U	V	W
							max	min												
J11A	4.94:1	137	16	42	65	83	350	240	12	14	35	76	50	65	90	105	140	200	108	83
J11B	4.94:1	137	16	42	65	83	350	240	12	14	35	76	50	65	90	105	140	200	108	83
J21A	5.00:1	157	18	52	81	100	400	280	16	18	45	86	52	70	96	114	160	236	118	99
J21B	5.00:1	157	18	52	81	100	400	280	16	18	45	86	52	70	96	114	160	236	118	99
J31A	5.00:1	172	16	62	84	114	400	280	16	18	50	104	57	79	110	132	180	272	134	120
J31B	5.00:1	172	16	62	84	114	400	280	16	18	50	104	57	79	110	132	180	272	134	120
J51A	5.08:1	189	10	82	105	138	460	330	20	22	55	104	62	87	118	143	355	320	160	146
J51B	5.08:1	189	10	82	105	138	460	330	20	22	55	104	62	87	118	143	355	320	160	146
J71A	4.94:1	203	16	87	114	166	460	330	20	22	75	134	60	85	123	148	355	388	200	167
J71B	4.94:1	203	16	87	114	166	460	330	20	22	75	134	60	85	123	148	355	388	200	167

Size	Ratio	X	Y	Z	Input shaft				Shaft sleeve ⁵			HF	AK	Weight kg
					F ⁶	H ⁷	G	FA	D ^{3,8}	B ⁴	E			
J11A	4.94:1	272	15	28	19	6	21.5	-	35	10	38.3	1	130	16
J11B	4.94:1	272	15	28	19	6	21.5	-	45	14	48.8	1	130	16
J21A	5.00:1	318	15	35	24	8	27	-	45	14	48.8	2	149	24
J21B	5.00:1	318	15	35	24	8	27	-	55	16	59.3	2	149	24
J31A	5.00:1	360	20	31	28	8	31	-	55	16	59.3	2	161	35
J31B	5.00:1	360	20	31	28	8	31	-	65	16	69.4	2	161	35
J51A	5.08:1	443	20	40	38	10	41	M8	60	18	64.4	2	178	53
J51B	5.08:1	443	20	40	38	10	41	M8	75	20	79.9	2	178	53
J71A	4.94:1	508	24	48	42	12	45	M8	70	20	74.9	2	192	82
J71B	4.94:1	508	24	48	42	12	45	M8	85	22	90.4	2	192	82

notes

- The V-belt pulley should be placed as close to the housing as possible.
- These dimensions are minimum diameters of driven pulley to prevent overloading of the bearings.
- Tolerances according to ISO H7.
- Tolerances according to ISO E9.
- The reducer should normally be mounted on a shaft with tolerance ISO js6. On heavy duty applications closer tolerances are recommended.
- Tolerances according to ISO js6.
- Tolerances according to ISO h9.
- Space for spacer if locking ring is used.

SERIES J

DIMENSIONS - SINGLE REDUCTION KIBO

J11 - 71 Single Reduction

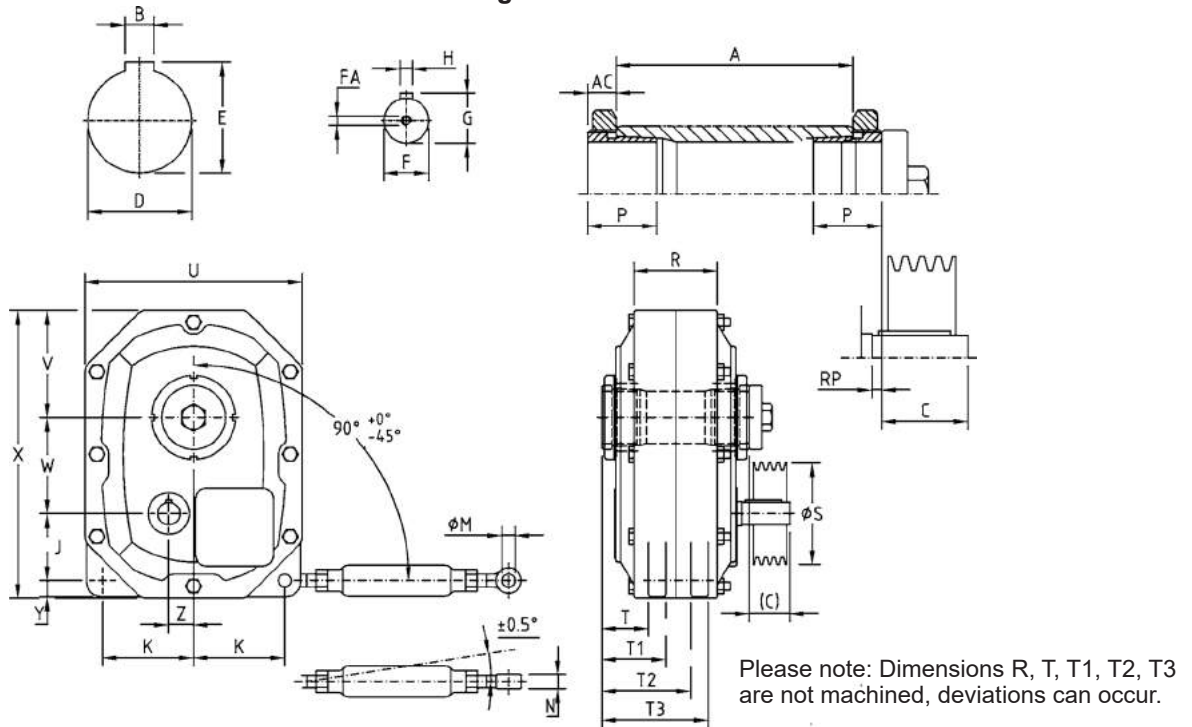

Size	Ratio	A	AC	C ¹	J	K	L		M	N	P	R	T	T1	T2	T3	S ²	U	V	W
							max	min												
J11A	4.94:1	116	11.6	36.4	65	83	350	240	12	14	40	76	47	62	87	102	140	200	108	83
J11B	4.94:1	116	11.6	36.4	65	83	350	240	12	14	40	76	47	62	87	102	140	200	108	83
J21A	5.00:1	136	12.2	46	81	100	400	280	16	18	48.8	86	51	69	93	112	160	236	118	99
J21B	5.00:1	136	12.2	46	81	100	400	280	16	18	48.8	86	51	69	93	112	160	236	118	99
J31A	5.00:1	148	15.5	54	84	114	400	280	16	18	58	104	56	78	109	131	180	272	134	120
J31B	5.00:1	148	15.5	54	84	114	400	280	16	18	58	104	56	78	109	131	180	272	134	120
J51A	5.08:1	168	16.4	72.6	105	138	460	330	20	22	61	104	68	93	124	149	355	320	160	146
J51B	5.08:1	168	16.4	72.6	105	138	460	330	20	22	61	104	68	93	124	149	355	320	160	146
J71A	4.94:1	182	19.5	72.5	114	166	460	330	20	22	67.5	134	64	89	127	152	355	388	200	167
J71B	4.94:1	182	19.5	72.5	114	166	460	330	20	22	67.5	134	64	89	127	152	355	388	200	167

Size	Ratio	X	Y	Z	Input shaft				Shaft sleeve ⁵			RP	Weight kg
					F ⁶	H ⁷	G	FA	D ^{3,8}	B ⁴	E		
J11A	4.94:1	272	15	28	19	6	21.5	-	35	10	38.3	3.6	16
J11B	4.94:1	272	15	28	19	6	21.5	-	45	14	48.8	3.6	16
J21A	5.00:1	318	15	35	24	8	27	-	45	14	48.8	3.9	24
J21B	5.00:1	318	15	35	24	8	27	-	55	16	59.3	3.9	24
J31A	5.00:1	360	20	31	28	8	31	-	55	16	59.3	6	35
J31B	5.00:1	360	20	31	28	8	31	-	65	16	69.4	6	35
J51A	5.08:1	443	20	40	38	10	41	M8	60	18	64.4	7.4	53
J51B	5.08:1	443	20	40	38	10	41	M8	75	20	79.9	7.4	53
J71A	4.94:1	508	24	48	42	12	45	M8	70	20	74.9	12.5	82
J71B	4.94:1	508	24	48	42	12	45	M8	85	22	90.4	12.5	82

notes

1. The V-belt pulley should be placed as close to the housing as possible.
2. These dimensions are minimum diameters of driven pulley to prevent overloading of the bearings.
3. Tolerances according to ISO H7.
4. Tolerances according to ISO E9.
5. The reducer should normally be mounted on a shaft with tolerance ISO js6. On heavy duty applications closer tolerances are recommended.
6. Tolerances according to ISO js6.
7. Tolerances according to ISO h9.
8. Space for spacer if locking ring is used.

SERIES J

DIMENSIONS - SINGLE REDUCTION

J100 Single Reduction

Dimensions for threaded holes at gearhouse sides, see page 53.

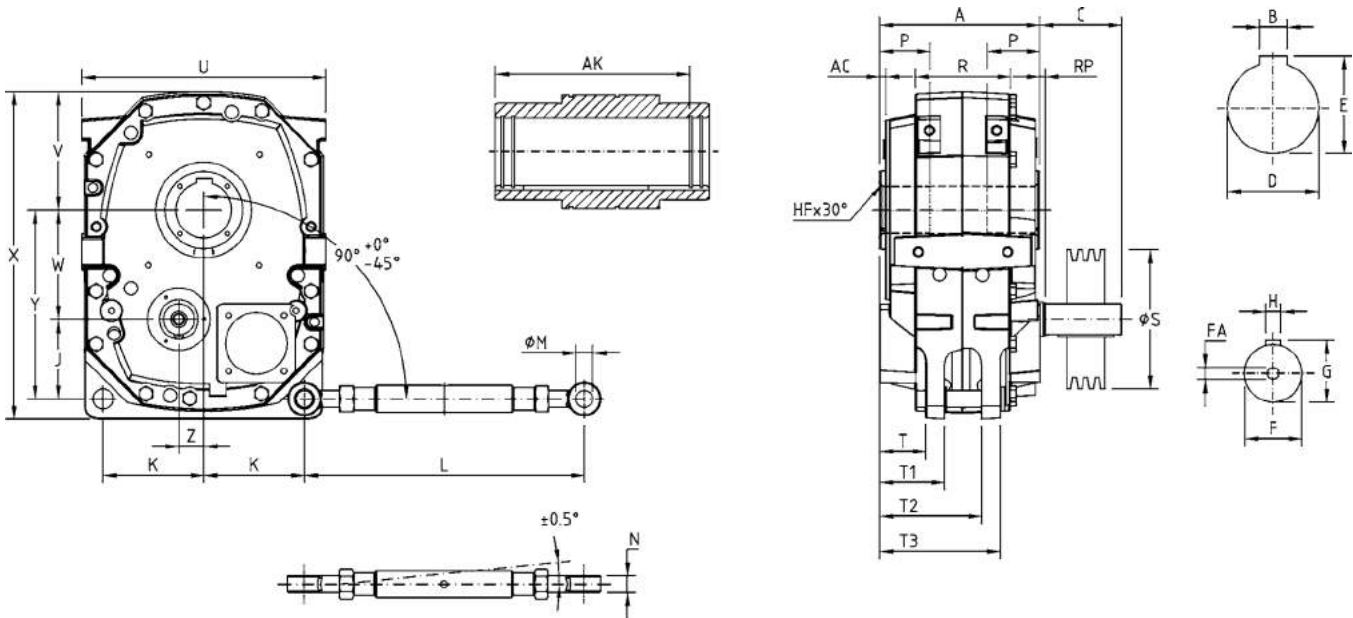

Please note: Dimensions R, T, T1, T2, T3 are not machined, deviations can occur.

Size	Ratio	A	AC	C ¹	RP	J	K	L		M	N	P	R	T	T1	T2	T3	S ²	U	V	W
								max	min												
J100	5:1	286	10	146	6	142	180	755	500	30	30	100	170	83	116	182	215	224	436	211	195

Size	Ratio	X	Y	Z	Input shaft				Shaft sleeve ⁵			HF	AK ⁵	Weight kg
					F ⁶	H ⁷	G	FA	D ^{3,8}	B ⁴	E			
J100	5:1	584	337	44.4	55	16	59	M20	100	28	106.4	3	249	206

notes

1. The V-belt pulley should be placed as close to the housing as possible.
2. These dimensions are minimum diameters of driven pulley to prevent overloading of the bearings.
3. Tolerances according to ISO H7.
4. Tolerances according to ISO E9.
5. The reducer should normally be mounted on a shaft with tolerance ISO js6. On heavy duty applications closer tolerances are recommended.
6. Tolerances according to ISO m6.
7. Tolerances according to ISO h9.
8. Space for spacer if locking ring is used.

SERIES J

DIMENSIONS - SINGLE REDUCTION KIBO

J100 Single Reduction

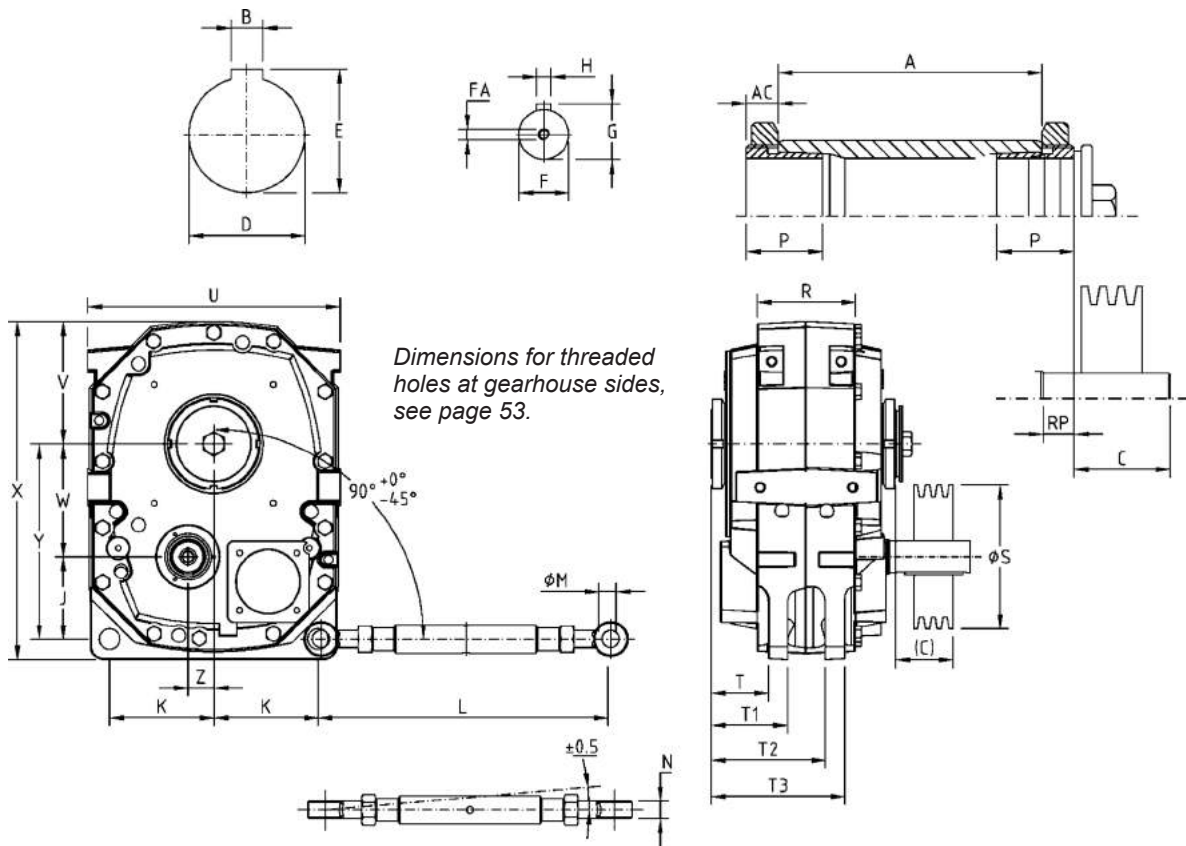

Dimensions for threaded holes at gearhouse sides, see page 53.

Please note: Dimensions R, T, T1, T2, T3 are not machined, deviations can occur.

Size	Ratio	A	AC	C ¹	RP	J	K	L		M	N	P	R	T	T1	T2	T3	S ²
								max	min									
J100	5:1	274	22	129	11	142	180	755	500	30	30	83	170	98	131	197	230	224

Size	Ratio	U	V	W	X	Y	Z	Input shaft				Shaft sleeve ⁵			Weight kg
								F ⁶	H ⁷	G	FA	D ^{3,8}	B ⁴	E	
J100	5:1	436	211	195	584	337	44.4	55	16	59	M20	100	28	106.4	208

notes

1. The V-belt pulley should be placed as close to the housing as possible.
2. These dimensions are minimum diameters of driven pulley to prevent overloading of the bearings.
3. Tolerances according to ISO H7.
4. Tolerances according to ISO E9.
5. The reducer should normally be mounted on a shaft with tolerance ISO h8. On heavy duty applications closer tolerances are recommended.
6. Tolerances according to ISO m6.
7. Tolerances according to ISO h9.
8. Space for spacer if locking ring is used.

SERIES J

DIMENSIONS - DOUBLE REDUCTION

J12 - 72 Double Reduction

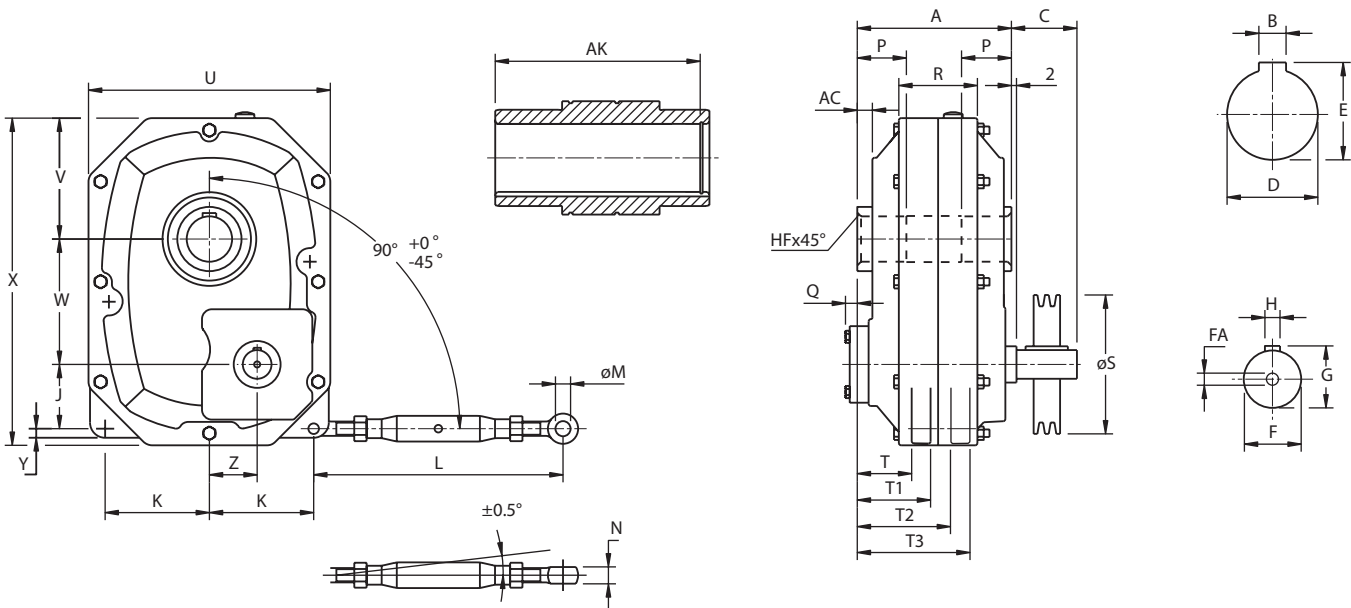

Please note: Dimensions R, T, T1, T2, T3 are not machined, deviations can occur.

Size	Ratio	A	AC	J	K	L		M	N	P	Q	R	T	T1	T2	T3	S ²	U	V	W	X	Y	Z
						max	min																
J12A	15/25:1	137	14	47	83	350	240	12	14	35	0	76	50	65	94	109	140	200	108	100	272	15	29
J12B	15/25:1	137	14	47	83	350	240	12	14	35	0	76	50	65	94	109	140	200	108	100	272	15	29
J22A	15/25:1	157	14	63	100	400	280	16	18	45	5	86	52	70	96	114	160	236	118	119	318	15	38
J22B	15/25:1	157	14	63	100	400	280	16	18	45	5	86	52	70	96	114	160	236	118	119	318	15	38
J32A	15/25:1	172	15	67	114	400	280	16	18	50	3	104	57	79	114	136	180	272	134	137	360	20	51
J32B	15/25:1	172	15	67	114	400	280	16	18	50	3	104	57	79	114	136	180	272	134	137	360	20	51
J52A	15/25:1	189	15	85	138	460	330	20	22	55	4	104	64	89	125	150	200	320	160	166	443	20	63
J52B	15/25:1	189	15	85	138	460	330	20	22	55	4	104	64	89	125	150	200	320	160	166	443	20	63
J72A	15/25:1	203	16	87	166	460	330	20	22	75	4	134	60	85	123	148	280	388	200	193	508	24	75.5
J72B	15/25:1	203	16	87	166	460	330	20	22	75	4	134	60	85	123	148	280	388	200	193	508	24	75.5

Size	Ratio	C ¹	Input shaft				Shaft sleeve ⁵					AK	Weight kg
			F ⁶	H ⁷	G	FA	D ^{3,8}	B ⁴	E	HF			
J12A	15/25:1	42	19	6	21.5	-	35	10	38.3	1	130	20	
J12B	15/25:1	42	19	6	21.5	-	45	14	48.8	1	130	20	
J22A	15:1	52	24	8	27	-	45	14	48.8	2	149	28	
J22B	15:1	52	24	8	27	-	55	16	59.3	2	149	28	
J22A	25:1	52	19	6	21.5	-	45	14	48.8	2	149	28	
J22B	25:1	52	19	6	21.5	-	55	16	59.3	2	149	28	
J32A	15:1	62	28	8	31	-	55	16	59.3	2	161	39	
J32B	15:1	62	28	8	31	-	65	18	69.4	2	161	39	
J32A	25:1	52	24	8	27	-	55	16	59.3	2	161	39	
J32B	25:1	52	24	8	27	-	65	18	69.4	2	161	39	
J52A	15:1	82	38	10	41	M8	60	18	64.4	2	178	60	
J52B	15:1	82	38	10	41	M8	75	20	79.9	2	178	60	
J52A	25:1	62	28	8	31	M8	60	18	64.4	2	178	60	
J52B	25:1	62	28	8	31	M8	75	20	79.9	2	178	60	
J72A	15:1	87	42	12	45	M8	70	20	74.9	2	192	90	
J72B	15:1	87	42	12	45	M8	85	22	90.4	2	192	90	
J72A	25:1	87	38	10	41	M8	70	20	74.9	2	192	90	
J72B	25:1	87	38	10	41	M8	85	22	90.4	2	192	90	

notes

- The V-belt pulley should be placed as close to the housing as possible.
- These dimensions are minimum diameters of driven pulley to prevent overloading of the bearings.
- Tolerances according to ISO H7.
- Tolerances according to ISO E9.
- The reducer should normally be mounted on a shaft with tolerance ISO js6. On heavy duty applications closer tolerances are recommended.
- Tolerances according to ISO m6.
- Tolerances according to ISO h6.
- Space for spacer if locking ring is used.

SERIES J

DIMENSIONS - DOUBLE REDUCTION KIBO

J12 - 72 Double Reduction

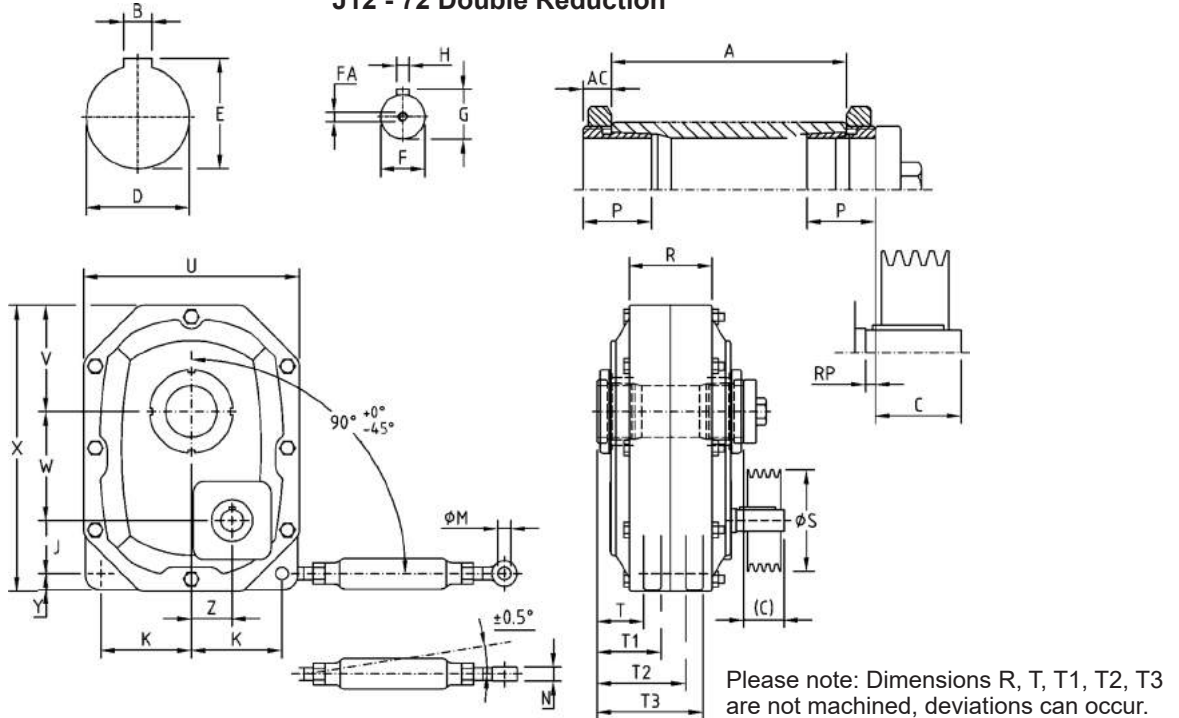

Size	Ratio	A	AC	J	K	L		M	N	P	Q	R	T	T1	T2	T3	S ²	U	V	W	X	Y	Z
						max	min																
J12A	15/25:1	116	11.6	47	83	350	240	12	14	40	0	76	47	62	87	102	140	200	108	100	272	15	29
J12B	15/25:1	116	11.6	47	83	350	240	12	14	40	0	76	47	62	87	102	140	200	108	100	272	15	29
J22A	15/25:1	136	12.2	63	100	400	280	16	18	48.8	5	86	51	69	93	112	160	236	118	119	318	15	38
J22B	15/25:1	136	12.2	63	100	400	280	16	18	48.8	5	86	51	69	93	112	160	236	118	119	318	15	38
J32A	15/25:1	148	15.5	67	114	400	280	16	18	58	3	104	56	78	109	131	180	272	134	137	360	20	51
J32B	15/25:1	148	15.5	67	114	400	280	16	18	58	3	104	56	78	109	131	180	272	134	137	360	20	51
J52A	15/25:1	168	16.4	85	138	460	330	20	22	61	4	104	68	93	124	149	200	320	160	166	443	20	63
J52B	15/25:1	168	16.4	85	138	460	330	20	22	61	4	104	68	93	124	149	200	320	160	166	443	20	63
J72A	15/25:1	182	19.5	87	166	460	330	20	22	67.5	4	134	64	89	127	152	280	388	200	193	508	24	75.5
J72B	15/25:1	182	19.5	87	166	460	330	20	22	67.5	4	134	64	89	127	152	280	388	200	193	508	24	75.5

Size	Ratio	C ¹	Input shaft				Shaft sleeve ⁵				Weight kg
			F ⁶	H ⁷	G	FA	D ^{3,8}	B ⁴	E	RP	
J12A	15/25:1	36.4	19	6	21.5	-	35	10	38.3	3.6	20
J12B	15/25:1	36.4	19	6	21.5	-	45	14	48.8	3.6	20
J22A	15:1	45.8	24	8	27	-	45	14	48.8	4.2	28
J22B	15:1	45.8	24	8	27	-	55	16	59.3	4.2	28
J22A	25:1	45.8	19	6	21.5	-	45	14	48.8	4.2	28
J22B	25:1	45.8	19	6	21.5	-	55	16	59.3	4.2	28
J32A	15:1	54	28	8	31	-	55	16	59.3	6	39
J32B	15:1	54	28	8	31	-	65	18	69.4	6	39
J32A	25:1	44	24	8	27	-	55	16	59.3	6	39
J32B	25:1	44	24	8	27	-	65	18	69.4	6	39
J52A	15:1	73.6	38	10	41	M8	60	18	64.4	6.4	60
J52B	15:1	73.6	38	10	41	M8	75	20	79.9	6.4	60
J52A	25:1	53.6	28	8	31	M8	60	18	64.4	6.4	60
J52B	25:1	53.6	28	8	31	M8	75	20	79.9	6.4	60
J72A	15:1	72.5	42	12	45	M8	70	20	74.9	12.5	90
J72B	15:1	72.5	42	12	45	M8	85	22	90.4	12.5	90
J72A	25:1	72.5	38	10	41	M8	70	20	74.9	12.5	90
J72B	25:1	72.5	38	10	41	M8	85	22	90.4	12.5	90

notes

1. The V-belt pulley should be placed as close to the housing as possible.
2. These dimensions are minimum diameters of driven pulley to prevent overloading of the bearings.
3. Tolerances according to ISO H7.
4. Tolerances according to ISO E9.
5. The reducer should normally be mounted on a shaft with tolerance ISO h8. On heavy duty applications closer tolerances are recommended.
6. Tolerances according to ISO js6.
7. Tolerances according to ISO js6.
8. Space for spacer if locking ring is used.

SERIES J

DIMENSIONS - DOUBLE REDUCTION

J100 Double Reduction

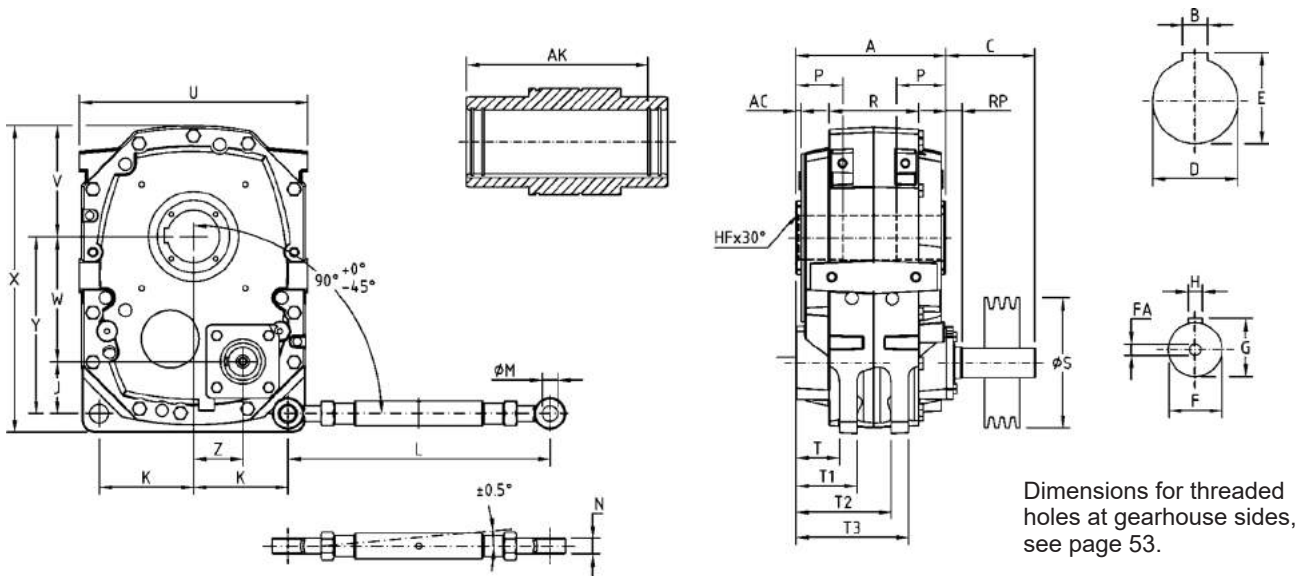

Dimensions for threaded holes at gearhouse sides, see page 53.

Please note: Dimensions R, T, T1, T2, T3 are not machined, deviations can occur.

Size	Ratio	A	AC	C ¹	RP	J	K	L		M	N	P	R	T	T1	T2	T3	S ²	U	V	W
								max	min												
J100	15/20/25:1	286	10	171.5	31.5	99	180	755	500	30	30	100	170	83	116	182	215	224	436	211	238

Size	Ratio	X	Y	Z	Input shaft				Shaft sleeve ⁵				AK	Weight kg
					F ⁶	H ⁷	G	FA	D ^{3,8}	B ⁴	E	HF		
J100	15/20/25:1	584	337	94	55	16	59	M20	100	28	106.4	3	249	236

notes

1. The V-belt pulley should be placed as close to the housing as possible.
2. These dimensions are minimum diameters of driven pulley to prevent overloading of the bearings.
3. Tolerances according to ISO H7.
4. Tolerances according to ISO E9.
5. The reducer should normally be mounted on a shaft with tolerance ISO js6. On heavy duty applications closer tolerances are recommended.
6. Tolerances according to ISO m6.
7. Tolerances according to ISO h9.
8. Space for spacer if locking ring is used.

SERIES J

DIMENSIONS - DOUBLE REDUCTION KIBO

J100 Double Reduction

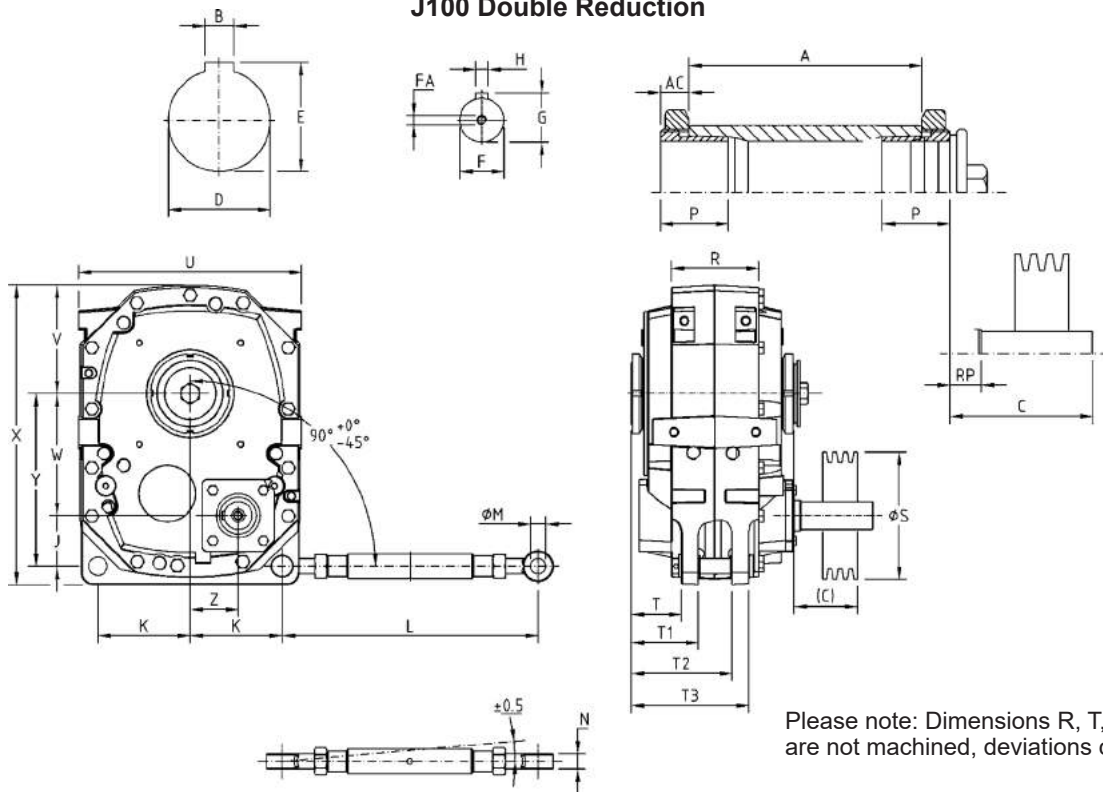

Please note: Dimensions R, T, T1, T2, T3 are not machined, deviations can occur.

Size	Ratio	A	AC	C ¹	RP	J	K	L		M	N	P	R	T	T1	T2	T3	S ²	U	V	W
								max	min												
J100	15/20/25:1	274	22	154.5	14.5	99	180	755	500	30	30	83	170	98	131	197	230	224	436	211	238

Size	Ratio	X	Y	Z	Input shaft				Shaft sleeve ⁵			Weight kg
					F ⁶	H ⁷	G	FA	D ^{3,8}	B ⁴	E	
J100	15/20/25:1	584	337	94	55	16	59	M20	100	28	106.4	238

notes

1. The V-belt pulley should be placed as close to the housing as possible.
2. These dimensions are minimum diameters of driven pulley to prevent overloading of the bearings.
3. Tolerances according to ISO H7.
4. Tolerances according to ISO E9.
5. The reducer should normally be mounted on a shaft with tolerance ISO js6. On heavy duty applications closer tolerances are recommended.
6. Tolerances according to ISO m6.
7. Tolerances according to ISO h9.
8. Space for spacer if locking ring is used.

SERIES J

POWER RATINGS V-BELT TRANSMISSIONS

0.37 kW

n2 rpm	T2 Nm	Gear unit	i	fbp SF	V-belt length SF	Motor	V-belt length mm	Pulley Ratio	Pulley D1	Pulley D2	Pulley type	C-C mm	Motor-mount type
6	564	J12	25	1,41	1,13	90S-8	1250	4,48	50	224	1SPZ	400	T
6	581	J12	25	1,37	1,11	*80C-8	1250	4,48	50	224	1SPZ	400	T
7	479	J12	25	1,67	1,14	90S-8	1180	3,80	50	190	1SPZ	395	T
7	534	J12	25	1,49	1,14	90S-8	1250	4,24	50	212	1SPZ	411	T
7	504	J12	25	1,58	1,13	90S-8	1180	4,00	50	200	1SPZ	386	T
7	493	J12	25	1,62	1,11	*80C-8	1180	3,80	50	190	1SPZ	395	T
7	519	J12	25	1,54	1,10	*80C-8	1180	4,00	50	200	1SPZ	386	T
8	454	J12	25	1,76	1,14	90S-8	1180	3,60	50	180	1SPZ	403	T
8	467	J12	25	1,71	1,12	*80C-8	1180	3,60	50	180	1SPZ	403	T

0.55 kW

8	629	J12	25	1,27	1,25	80B-6	1320	4,46	56	250	1SPZ	407	T
9	564	J12	25	1,42	1,25	80B-6	1250	4,00	56	224	1SPZ	396	T
9	594	J12	25	1,35	1,24	80B-6	1250	4,21	56	236	1SPZ	384	T
10	534	J12	25	1,50	1,26	80B-6	1250	3,79	56	212	1SPZ	406	T
10	504	J12	25	1,59	1,25	80B-6	1180	3,57	56	200	1SPZ	381	T
11	478	J12	25	1,68	1,26	80B-6	1180	3,39	56	190	1SPZ	390	T
12	453	J12	25	1,77	1,26	80B-6	1180	3,21	56	180	1SPZ	399	T

0.75 kW

6	1117	J22	25	1,34	1,14	100LA-8	1320	4,48	50	224	2SPZ	435	T
6	1150	J22	25	1,30	1,11	*90LB-8	1320	4,48	50	224	2SPZ	435	T
7	1057	J22	25	1,42	1,15	100LA-8	1320	4,24	50	212	2SPZ	446	T
7	998	J22	25	1,50	1,13	100LA-8	1250	4,00	50	200	2SPZ	421	T
7	976	J22	25	1,54	1,11	*90LB-8	1250	3,80	50	190	2SPZ	430	T
7	1027	J22	25	1,46	1,11	*90LB-8	1250	4,00	50	200	2SPZ	421	T
7	1089	J22	25	1,38	1,10	*90LB-8	1250	4,24	50	212	2SPZ	411	T
8	898	J22	25	1,68	1,15	100LA-8	1250	3,60	50	180	2SPZ	439	T
8	948	J22	25	1,59	1,14	100LA-8	1250	3,80	50	190	2SPZ	430	T
8	924	J22	25	1,63	1,12	*90LB-8	1250	3,60	50	180	2SPZ	439	T
11	636	J12	15	1,26	1,09	*90LB-8	1180	4,00	50	200	2SPZ	386	T
12	617	J12	15	1,30	1,13	100LA-8	1250	4,00	50	200	2SPZ	421	T
12	604	J12	15	1,33	1,10	*90LB-8	1180	3,80	50	190	2SPZ	395	T
13	562	J12	25	1,43	1,32	80B-4	1320	4,46	56	250	1SPZ	407	T
13	556	J12	15	1,44	1,13	100LA-8	1180	3,60	50	180	2SPZ	403	T
13	540	J12	15	1,48	1,11	*90LB-8	1180	3,40	50	170	2SPZ	412	T
13	531	J12	25	1,51	1,30	80B-4	1250	4,21	56	236	1SPZ	384	T
13	572	J12	15	1,40	1,10	*90LB-8	1180	3,60	50	180	2SPZ	403	T
14	504	J12	25	1,59	1,32	80B-4	1250	4,00	56	224	1SPZ	396	T
14	525	J12	15	1,52	1,14	100LA-8	1180	3,40	50	170	2SPZ	412	T
15	477	J12	25	1,68	1,33	80B-4	1250	3,79	56	212	1SPZ	406	T
16	449	J12	25	1,78	1,07	90S-6	1120	2,33	60	140	1SPZ	400	T
16	450	J12	25	1,78	1,31	80B-4	1180	3,57	56	200	1SPZ	381	T
16	458	J12	25	1,74	1,05	*80C-6	1120	2,33	60	140	1SPZ	400	T

1.10 kW

6	1624	J32	25	1,35	1,39	100LB-8	1500	4,48	67	300	2SPZ	446	N
7	1447	J22	25	1,04	1,39	100LB-8	1400	3,96	67	265	2SPZ	427	T
8	1353	J32	25	1,62	1,40	100LB-8	1400	3,73	67	250	2SPZ	441	N
8	1365	J22	25	1,10	1,40	100LB-8	1400	3,73	67	250	2SPZ	441	T
12	903	J22	15	1,66	1,39	100LB-8	1400	3,96	67	265	2SPZ	427	T
12	852	J22	15	1,76	1,40	100LB-8	1400	3,73	67	250	2SPZ	441	T
13	798	J12	15	1,00	1,39	100LB-8	1320	3,52	67	236	2SPZ	413	T
14	757	J12	15	1,05	1,40	100LB-8	1320	3,34	67	224	2SPZ	424	T
14	755	J12	25	1,06	1,00	90L-6	1250	2,68	71	190	1SPZ	415	T
18	596	J12	25	1,34	1,00	90L-6	1180	2,11	71	150	1SPZ	414	T
20	526	J12	25	1,52	1,08	90L-6	1120	1,87	75	140	1SPZ	389	T
20	526	J12	25	1,52	1,10	90L-6	1180	1,87	75	140	1SPZ	419	T
21	493	J12	25	1,62	1,22	90L-6	1180	1,75	80	140	1SPZ	415	T
21	493	J12	25	1,62	1,20	90L-6	1120	1,75	80	140	1SPZ	385	T
23	464	J12	25	1,72	1,33	90L-6	1180	1,65	85	140	1SPZ	412	T
23	456	J12	15	1,75	1,00	90L-6	1250	2,68	71	190	1SPZ	415	T
24	443	J12	25	1,80	1,03	*80C-4	1120	2,33	60	140	1SPZ	400	T

*High efficiency motor

SERIES J

POWER RATINGS V-BELT TRANSMISSIONS

1.50 kW

n2 rpm	T2 Nm	Gear unit	i	fbp SF	V-belt length SF	Motor	V-belt length mm	Pulley Ratio	Pulley D1	Pulley D2	Pulley type	C-C mm	Motor- mount type
6	2260	J52	25	1,28	1,18	112M-8	1800	4,44	71	315	2SPZ	583	T
6	2244	J52	25	1,29	1,19	*100LC-8	1800	4,44	71	315	2SPZ	583	T
7	2009	J52	25	1,44	1,16	112M-8	1600	3,94	71	280	2SPZ	513	N
7	2153	J52	25	1,35	1,14	112M-8	1600	4,23	71	300	2SPZ	495	N
7	1964	J32	25	1,12	1,13	112M-8	1500	3,94	71	280	2SPZ	462	N
7	1995	J52	25	1,45	1,16	*100LC-8	1600	3,94	71	280	2SPZ	513	N
7	2137	J52	25	1,36	1,15	*100LC-8	1600	4,23	71	300	2SPZ	495	N
7	1950	J32	25	1,13	1,14	*100LC-8	1500	3,94	71	280	2SPZ	462	N
7	2090	J32	25	1,05	1,12	*100LC-8	1500	4,23	71	300	2SPZ	443	N
7	2153	J52	25	1,35	1,19	112M-8	1800	4,23	71	300	2SPZ	597	T
7	2009	J52	25	1,44	1,18	112M-8	1700	3,94	71	280	2SPZ	564	T
7	1964	J32	25	1,12	1,16	112M-8	1600	3,94	71	280	2SPZ	513	T
7	2105	J32	25	1,04	1,14	112M-8	1600	4,23	71	300	2SPZ	495	T
7	1995	J52	25	1,45	1,18	*100LC-8	1700	3,94	71	280	2SPZ	564	T
7	2090	J32	25	1,05	1,15	*100LC-8	1600	4,23	71	300	2SPZ	495	T
7	2194	J32	25	1,00	1,14	*100LC-8	1600	4,44	71	315	2SPZ	481	T
8	1901	J52	25	1,53	1,16	112M-8	1600	3,73	71	265	2SPZ	526	N
8	1859	J32	25	1,18	1,14	112M-8	1500	3,73	71	265	2SPZ	476	N
8	1794	J52	25	1,62	1,19	112M-8	1700	3,52	71	250	2SPZ	590	T
8	1901	J52	25	1,53	1,18	112M-8	1700	3,73	71	265	2SPZ	577	T
8	1888	J52	25	1,54	1,19	*100LC-8	1700	3,73	71	265	2SPZ	577	T
8	1846	J32	25	1,19	1,15	*100LC-8	1500	3,73	71	265	2SPZ	476	T
11	1256	J32	15	1,75	1,13	112M-8	1500	3,94	71	280	2SPZ	462	N
11	1247	J32	15	1,76	1,14	*100LC-8	1500	3,94	71	280	2SPZ	462	N
11	1256	J32	15	1,75	1,16	112M-8	1600	3,94	71	280	2SPZ	513	T
12	1237	J22	15	1,21	1,13	112M-8	1500	3,94	71	280	2SPZ	462	T
12	1162	J22	15	1,29	1,12	*100LC-8	1400	3,73	71	265	2SPZ	424	T
13	1091	J22	25	1,37	1,04	90L-4	1500	4,44	71	315	1SPZ	429	T
13	1104	J22	15	1,36	1,13	112M-8	1400	3,52	71	250	2SPZ	438	T
13	1097	J22	15	1,37	1,13	*100LC-8	1400	3,52	71	250	2SPZ	438	T
14	1039	J22	25	1,44	1,05	90L-4	1500	4,23	71	300	1SPZ	443	T
14	1043	J22	15	1,44	1,14	112M-8	1400	3,32	71	236	2SPZ	451	T
14	1035	J22	15	1,45	1,14	*100LC-8	1400	3,32	71	236	2SPZ	451	T
15	970	J22	25	1,55	1,04	90L-4	1400	3,94	71	280	1SPZ	410	T
16	918	J22	25	1,63	1,05	90L-4	1400	3,73	71	265	1SPZ	424	T
17	866	J22	25	1,73	1,06	90L-4	1400	3,52	71	250	1SPZ	438	T
19	752	J12	25	1,07	1,05	90L-4	1250	2,99	71	212	1SPZ	396	T
20	709	J12	25	1,13	1,05	90L-4	1250	2,82	71	200	1SPZ	406	T
21	674	J12	25	1,19	1,06	90L-4	1250	2,68	71	190	1SPZ	415	T
22	638	J12	25	1,25	1,05	90L-4	1180	2,54	71	180	1SPZ	388	T
22	643	J12	15	1,24	1,02	90L-4	1400	4,23	71	300	1SPZ	391	T
23	620	J12	25	1,29	1,00	100L-6	1180	1,65	85	140	1SPZ	412	T
24	603	J12	25	1,33	1,05	90L-4	1180	2,39	71	170	1SPZ	397	T
24	600	J12	15	1,33	1,04	90L-4	1400	3,94	71	280	1SPZ	410	T
25	567	J12	25	1,41	1,06	90L-4	1180	2,25	71	160	1SPZ	405	T
27	532	J12	25	1,51	1,06	90L-4	1180	2,11	71	150	1SPZ	414	T
27	532	J12	25	1,51	1,05	90L-4	1120	2,11	71	150	1SPZ	384	T
27	536	J12	15	1,49	1,04	90L-4	1320	3,52	71	250	1SPZ	397	T
28	506	J12	15	1,58	1,05	90L-4	1320	3,32	71	236	1SPZ	410	T
29	497	J12	25	1,61	1,05	90L-4	1120	1,97	71	140	1SPZ	392	T
30	470	J12	25	1,70	1,17	90L-4	1180	1,87	75	140	1SPZ	419	T
30	470	J12	25	1,70	1,15	90L-4	1120	1,87	75	140	1SPZ	389	T
32	454	J12	15	1,76	1,05	90L-4	1250	2,99	71	212	1SPZ	396	T
73	196	J11	5	1,61	1,01	90L-4	1320	3,94	71	280	1SPZ	369	T
77	186	J11	5	1,67	1,03	90L-4	1320	3,73	71	265	1SPZ	383	T
82	175	J11	5	1,74	1,04	90L-4	1320	3,52	71	250	1SPZ	397	T
87	166	J11	5	1,80	1,03	90L-4	1250	3,32	71	236	1SPZ	374	T
7	2811	J72	25	1,78	1,11	132S-8	1900	3,94	85	335	2SPZ	607	N
7	2979	J72	25	1,68	1,10	132S-8	1900	4,18	85	355	2SPZ	588	N
7	2811	J72	25	1,78	1,13	132S-8	2000	3,94	85	335	2SPZ	658	T
7	3146	J72	25	1,59	1,13	132S-8	2120	4,41	85	375	2SPZ	683	T
7	2843	J52	25	1,02	1,11	132S-8	1900	3,94	85	335	2SPZ	607	T

2.20 kW

*High efficiency motor

SERIES J

POWER RATINGS V-BELT TRANSMISSIONS

2.20 kW

n2 rpm	T2 Nm	Gear unit	i	fbp SF	V-belt length SF	Motor	V-belt length mm	Pulley Ratio	Pulley D1	Pulley D2	Pulley type	C-C mm	Motor- mount type
8	2673	J52	25	1,09	1,08	132S-8	1700	3,71	85	315	2SPZ	522	N
9	2320	J52	25	1,25	1,13	112M-6	1700	4,20	75	315	2SPZ	529	N
9	2468	J52	25	1,18	1,12	112M-6	1700	4,47	75	335	2SPZ	511	N
9	2468	J52	25	1,18	1,12	*100LC-6	1700	4,47	75	335	2SPZ	511	N
9	2320	J52	25	1,25	1,15	112M-6	1800	4,20	75	315	2SPZ	581	T
9	2468	J52	25	1,18	1,14	112M-6	1800	4,47	75	335	2SPZ	562	T
9	2320	J52	25	1,25	1,15	*100LC-6	1800	4,20	75	315	2SPZ	581	T
9	2468	J52	25	1,18	1,14	*100LC-6	1800	4,47	75	335	2SPZ	562	T
10	2062	J52	25	1,41	1,13	112M-6	1600	3,73	75	280	2SPZ	510	N
10	2062	J52	25	1,41	1,13	*100LC-6	1600	3,73	75	280	2SPZ	510	N
10	2210	J52	25	1,31	1,12	*100LC-6	1600	4,00	75	300	2SPZ	492	N
10	2161	J32	25	1,02	1,09	*100LC-6	1500	4,00	75	300	2SPZ	440	N
10	2017	J32	25	1,09	1,10	112M-6	1500	3,73	75	280	2SPZ	459	N
10	2017	J32	25	1,09	1,10	*100LC-6	1500	3,73	75	280	2SPZ	459	N
10	2210	J52	25	1,31	1,16	112M-6	1800	4,00	75	300	2SPZ	594	T
10	2017	J32	25	1,09	1,13	112M-6	1600	3,73	75	280	2SPZ	510	T
10	2161	J32	25	1,02	1,12	112M-6	1600	4,00	75	300	2SPZ	492	T
10	2062	J52	25	1,41	1,15	*100LC-6	1700	3,73	75	280	2SPZ	561	T
10	2161	J32	25	1,02	1,12	*100LC-6	1600	4,00	75	300	2SPZ	492	T
11	1883	J32	15	1,17	1,06	132S-8	1700	4,18	85	355	2SPZ	485	N
11	1952	J52	25	1,49	1,14	112M-6	1600	3,53	75	265	2SPZ	524	N
11	1909	J32	25	1,15	1,11	112M-6	1500	3,53	75	265	2SPZ	473	N
11	1841	J52	25	1,57	1,12	*100LC-6	1500	3,33	75	250	2SPZ	486	N
11	1883	J32	15	1,17	1,08	132S-8	1800	4,18	85	355	2SPZ	537	T
11	1841	J52	25	1,57	1,16	112M-6	1700	3,33	75	250	2SPZ	588	T
11	1952	J52	25	1,49	1,16	112M-6	1700	3,53	75	265	2SPZ	574	T
11	1952	J52	25	1,49	1,16	*100LC-6	1700	3,53	75	265	2SPZ	574	T
11	1909	J32	25	1,15	1,11	*100LC-6	1500	3,53	75	265	2SPZ	473	T
11	1876	J52	15	1,55	1,10	132S-8	1900	4,18	85	355	2SPZ	588	T
12	1738	J52	25	1,67	1,13	112M-6	1500	3,15	75	236	2SPZ	499	N
12	1700	J32	25	1,29	1,11	112M-6	1400	3,15	75	236	2SPZ	448	N
12	1738	J52	25	1,67	1,13	*100LC-6	1500	3,15	75	236	2SPZ	499	N
12	1700	J32	25	1,29	1,11	*100LC-6	1400	3,15	75	236	2SPZ	448	N
12	1801	J32	25	1,22	1,10	*100LC-6	1400	3,33	75	250	2SPZ	435	N
12	1770	J52	15	1,64	1,11	132S-8	1900	3,94	85	335	2SPZ	607	T
12	1777	J32	15	1,24	1,07	132S-8	1700	3,94	85	335	2SPZ	504	T
12	1700	J32	25	1,29	1,13	112M-6	1500	3,15	75	236	2SPZ	499	T
12	1801	J32	25	1,22	1,12	112M-6	1500	3,33	75	250	2SPZ	486	T
12	1700	J32	25	1,29	1,13	*100LC-6	1500	3,15	75	236	2SPZ	499	T
12	1801	J32	25	1,22	1,12	*100LC-6	1500	3,33	75	250	2SPZ	486	T
13	1592	J32	15	1,38	1,07	132S-8	1600	3,53	85	300	2SPZ	485	N
13	1671	J32	15	1,32	1,06	132S-8	1600	3,71	85	315	2SPZ	471	N
13	1650	J52	25	1,76	1,14	112M-6	1500	2,99	75	224	2SPZ	509	N
13	1613	J32	25	1,36	1,12	112M-6	1400	2,99	75	224	2SPZ	458	N
13	1650	J52	25	1,76	1,14	*100LC-6	1500	2,99	75	224	2SPZ	509	N
13	1613	J32	25	1,36	1,12	*100LC-6	1400	2,99	75	224	2SPZ	458	N
13	1592	J32	15	1,38	1,09	132S-8	1700	3,53	85	300	2SPZ	536	T
13	1671	J32	15	1,32	1,08	132S-8	1700	3,71	85	315	2SPZ	522	T
13	1613	J32	25	1,36	1,14	112M-6	1500	2,99	75	224	2SPZ	509	T
13	1650	J52	25	1,76	1,16	*100LC-6	1600	2,99	75	224	2SPZ	560	T
14	1527	J32	25	1,44	1,12	112M-6	1400	2,83	75	212	2SPZ	469	N
14	1451	J32	15	1,52	1,11	112M-6	1600	4,20	75	315	2SPZ	478	N
14	1527	J32	25	1,44	1,12	*100LC-6	1400	2,83	75	212	2SPZ	469	N
14	1453	J22	25	1,03	1,11	112M-6	1320	2,67	75	200	2SPZ	439	T
14	1451	J32	15	1,52	1,11	*100LC-6	1600	4,20	75	315	2SPZ	478	T
14	1453	J22	25	1,03	1,11	*100LC-6	1320	2,67	75	200	2SPZ	439	T
15	1440	J32	25	1,53	1,13	112M-6	1400	2,67	75	200	2SPZ	479	N
15	1368	J32	25	1,61	1,12	112M-6	1320	2,53	75	190	2SPZ	448	N
15	1368	J32	25	1,61	1,12	*100LC-6	1320	2,53	75	190	2SPZ	448	N
15	1440	J32	25	1,53	1,11	*100LC-6	1320	2,67	75	200	2SPZ	439	N
15	1382	J32	15	1,59	1,09	*100LC-6	1500	4,00	75	300	2SPZ	440	N
15	1368	J32	25	1,61	1,13	112M-6	1400	2,53	75	190	2SPZ	488	T
15	1382	J32	15	1,59	1,12	112M-6	1600	4,00	75	300	2SPZ	492	T

*High efficiency motor

SERIES J

POWER RATINGS V-BELT TRANSMISSIONS

2.20 kW

n2 rpm	T2 Nm	Gear unit	i	fbp SF	V-belt length SF	Motor	V-belt length mm	Pulley Ratio	Pulley D1	Pulley D2	Pulley type	C-C mm	Motor- mount type
8	2673	J52	25	1,09	1,08	132S-8	1700	3,71	85	315	2SPZ	522	N
9	2320	J52	25	1,25	1,13	112M-6	1700	4,20	75	315	2SPZ	529	N
9	2468	J52	25	1,18	1,12	112M-6	1700	4,47	75	335	2SPZ	511	N
9	2468	J52	25	1,18	1,12	*100LC-6	1700	4,47	75	335	2SPZ	511	N
9	2320	J52	25	1,25	1,15	112M-6	1800	4,20	75	315	2SPZ	581	T
9	2468	J52	25	1,18	1,14	112M-6	1800	4,47	75	335	2SPZ	562	T
9	2320	J52	25	1,25	1,15	*100LC-6	1800	4,20	75	315	2SPZ	581	T
9	2468	J52	25	1,18	1,14	*100LC-6	1800	4,47	75	335	2SPZ	562	T
10	2062	J52	25	1,41	1,13	112M-6	1600	3,73	75	280	2SPZ	510	N
10	2062	J52	25	1,41	1,13	*100LC-6	1600	3,73	75	280	2SPZ	510	N
10	2210	J52	25	1,31	1,12	*100LC-6	1600	4,00	75	300	2SPZ	492	N
10	2161	J32	25	1,02	1,09	*100LC-6	1500	4,00	75	300	2SPZ	440	N
10	2017	J32	25	1,09	1,10	112M-6	1500	3,73	75	280	2SPZ	459	N
10	2017	J32	25	1,09	1,10	*100LC-6	1500	3,73	75	280	2SPZ	459	N
10	2210	J52	25	1,31	1,16	112M-6	1800	4,00	75	300	2SPZ	594	T
10	2017	J32	25	1,09	1,13	112M-6	1600	3,73	75	280	2SPZ	510	T
10	2161	J32	25	1,02	1,12	112M-6	1600	4,00	75	300	2SPZ	492	T
10	2062	J52	25	1,41	1,15	*100LC-6	1700	3,73	75	280	2SPZ	561	T
10	2161	J32	25	1,02	1,12	*100LC-6	1600	4,00	75	300	2SPZ	492	T
11	1883	J32	15	1,17	1,06	132S-8	1700	4,18	85	355	2SPZ	485	N
11	1952	J52	25	1,49	1,14	112M-6	1600	3,53	75	265	2SPZ	524	N
11	1909	J32	25	1,15	1,11	112M-6	1500	3,53	75	265	2SPZ	473	N
11	1841	J52	25	1,57	1,12	*100LC-6	1500	3,33	75	250	2SPZ	486	N
11	1883	J32	15	1,17	1,08	132S-8	1800	4,18	85	355	2SPZ	537	T
11	1841	J52	25	1,57	1,16	112M-6	1700	3,33	75	250	2SPZ	588	T
11	1952	J52	25	1,49	1,16	112M-6	1700	3,53	75	265	2SPZ	574	T
11	1952	J52	25	1,49	1,16	*100LC-6	1700	3,53	75	265	2SPZ	574	T
11	1909	J32	25	1,15	1,11	*100LC-6	1500	3,53	75	265	2SPZ	473	T
11	1876	J52	15	1,55	1,10	132S-8	1900	4,18	85	355	2SPZ	588	T
12	1738	J52	25	1,67	1,13	112M-6	1500	3,15	75	236	2SPZ	499	N
12	1700	J32	25	1,29	1,11	112M-6	1400	3,15	75	236	2SPZ	448	N
12	1738	J52	25	1,67	1,13	*100LC-6	1500	3,15	75	236	2SPZ	499	N
12	1700	J32	25	1,29	1,11	*100LC-6	1400	3,15	75	236	2SPZ	448	N
12	1801	J32	25	1,22	1,10	*100LC-6	1400	3,33	75	250	2SPZ	435	N
12	1770	J52	15	1,64	1,11	132S-8	1900	3,94	85	335	2SPZ	607	T
12	1777	J32	15	1,24	1,07	132S-8	1700	3,94	85	335	2SPZ	504	T
12	1700	J32	25	1,29	1,13	112M-6	1500	3,15	75	236	2SPZ	499	T
12	1801	J32	25	1,22	1,12	112M-6	1500	3,33	75	250	2SPZ	486	T
12	1700	J32	25	1,29	1,13	*100LC-6	1500	3,15	75	236	2SPZ	499	T
12	1801	J32	25	1,22	1,12	*100LC-6	1500	3,33	75	250	2SPZ	486	T
13	1592	J32	15	1,38	1,07	132S-8	1600	3,53	85	300	2SPZ	485	N
13	1671	J32	15	1,32	1,06	132S-8	1600	3,71	85	315	2SPZ	471	N
13	1650	J52	25	1,76	1,14	112M-6	1500	2,99	75	224	2SPZ	509	N
13	1613	J32	25	1,36	1,12	112M-6	1400	2,99	75	224	2SPZ	458	N
13	1650	J52	25	1,76	1,14	*100LC-6	1500	2,99	75	224	2SPZ	509	N
13	1613	J32	25	1,36	1,12	*100LC-6	1400	2,99	75	224	2SPZ	458	N
13	1592	J32	15	1,38	1,09	132S-8	1700	3,53	85	300	2SPZ	536	T
13	1671	J32	15	1,32	1,08	132S-8	1700	3,71	85	315	2SPZ	522	T
13	1613	J32	25	1,36	1,14	112M-6	1500	2,99	75	224	2SPZ	509	T
13	1650	J52	25	1,76	1,16	*100LC-6	1600	2,99	75	224	2SPZ	560	T
14	1527	J32	25	1,44	1,12	112M-6	1400	2,83	75	212	2SPZ	469	N
14	1451	J32	15	1,52	1,11	112M-6	1600	4,20	75	315	2SPZ	478	N
14	1527	J32	25	1,44	1,12	*100LC-6	1400	2,83	75	212	2SPZ	469	N
14	1453	J22	25	1,03	1,11	112M-6	1320	2,67	75	200	2SPZ	439	T
14	1451	J32	15	1,52	1,11	*100LC-6	1600	4,20	75	315	2SPZ	478	T
14	1453	J22	25	1,03	1,11	*100LC-6	1320	2,67	75	200	2SPZ	439	T
15	1440	J32	25	1,53	1,13	112M-6	1400	2,67	75	200	2SPZ	479	N
15	1368	J32	25	1,61	1,12	112M-6	1320	2,53	75	190	2SPZ	448	N
15	1368	J32	25	1,61	1,12	*100LC-6	1320	2,53	75	190	2SPZ	448	N
15	1440	J32	25	1,53	1,11	*100LC-6	1320	2,67	75	200	2SPZ	439	N
15	1382	J32	15	1,59	1,09	*100LC-6	1500	4,00	75	300	2SPZ	440	N
15	1368	J32	25	1,61	1,13	112M-6	1400	2,53	75	190	2SPZ	488	T
15	1382	J32	15	1,59	1,12	112M-6	1600	4,00	75	300	2SPZ	492	T

*High efficiency motor

SERIES J

POWER RATINGS V-BELT TRANSMISSIONS

2.20 kW

n2 rpm	T2 Nm	Gear unit	i	fbp SF	V-belt length SF	Motor	V-belt length mm	Pulley Ratio	Pulley D1	Pulley D2	Pulley type	C-C mm	Motor- mount type
41	518	J12	25	1,54	1,19	90L-2	1250	2,84	67	190	1SPZ	418	T
41	513	J12	25	1,56	1,24	100LA-4	1180	1,40	100	140	1SPZ	400	T
42	495	J12	15	1,62	1,14	90L-2	1400	4,48	67	300	1SPZ	394	T
42	498	J12	25	1,61	1,30	*90LB-4	1180	1,32	106	140	1SPZ	396	T
43	491	J12	25	1,63	1,17	90L-2	1180	2,69	67	180	1SPZ	391	T
43	484	J12	25	1,65	1,34	100LA-4	1180	1,32	106	140	1SPZ	396	T
45	464	J12	25	1,73	1,18	90L-2	1180	2,54	67	170	1SPZ	400	T
45	472	J12	25	1,70	1,40	*90LB-4	1180	1,25	112	140	1SPZ	391	T
24	646	J12	15	1,73	1,16	90L-2	1400	4,18	67	280	1SPZ	413	T
84	250	J11	5	1,21	1,09	*100LC-6	1180	2,27	75	170	2SPZ	394	T
89	235	J11	5	1,25	1,10	*100LC-6	1180	2,13	75	160	2SPZ	403	T
95	221	J11	5	1,31	1,09	*100LC-6	1120	2,00	75	150	2SPZ	381	T
95	221	J11	5	1,31	1,10	*100LC-6	1180	2,00	75	150	2SPZ	411	T
102	206	J11	5	1,37	1,09	*100LC-6	1120	1,87	75	140	2SPZ	389	T
109	193	J11	5	1,43	1,21	*100LC-6	1120	1,75	80	140	2SPZ	385	T
116	182	J11	5	1,49	1,35	*100LC-6	1180	1,65	85	140	2SPZ	412	T
116	182	J11	5	1,49	1,33	*100LC-6	1120	1,65	85	140	2SPZ	382	T

3.00 kW

7	3907	J72	25	1,28	1,18	132M-8	2120	4,02	112	450	2SPZ	594	N
7	4342	J72	25	1,15	1,17	132M-8	2240	4,46	112	500	2SPZ	608	N
7	4342	J72	25	1,15	1,19	132M-8	2360	4,46	112	500	2SPZ	670	T
7	3907	J72	25	1,28	1,20	132M-8	2240	4,02	112	450	2SPZ	656	T
8	3690	J72	25	1,36	1,21	132M-8	2240	3,79	112	425	2SPZ	679	T
9	3071	J72	25	1,63	1,22	132S-6	2000	4,21	95	400	2SPZ	591	N
9	3153	J72	25	1,59	1,19	*112MB-6	2000	4,21	95	400	2SPZ	591	N
9	3350	J72	25	1,49	1,18	*112MB-6	2000	4,47	95	425	2SPZ	567	N
9	3071	J72	25	1,63	1,25	132S-6	2120	4,21	95	400	2SPZ	653	T
9	3153	J72	25	1,59	1,22	*112MB-6	2120	4,21	95	400	2SPZ	653	T
10	2879	J72	25	1,74	1,24	132S-6	2000	3,95	95	375	2SPZ	614	N
10	2756	J72	25	1,05	1,21	132S-6	1800	3,74	95	355	2SPZ	530	N
10	2956	J72	25	1,69	1,19	*112MB-6	1900	3,95	95	375	2SPZ	563	N
10	2799	J72	25	1,79	1,20	*112MB-6	1900	3,74	95	355	2SPZ	581	N
10	2879	J72	25	1,74	1,26	132S-6	2120	3,95	95	375	2SPZ	676	T
10	2912	J52	25	1,00	1,24	132S-6	2000	3,95	95	375	2SPZ	614	T
10	2799	J72	25	1,79	1,22	*112MB-6	2000	3,74	95	355	2SPZ	632	T
10	2830	J52	25	1,03	1,20	*112MB-6	1900	3,74	95	355	2SPZ	581	T
11	2601	J52	25	1,11	1,22	132S-6	1800	3,53	95	335	2SPZ	548	N
11	2511	J52	25	1,15	1,18	*112MB-6	1700	3,32	95	315	2SPZ	516	N
11	2671	J52	25	1,09	1,17	*112MB-6	1700	3,53	95	335	2SPZ	497	N
11	2601	J52	25	1,11	1,24	132S-6	1900	3,53	95	335	2SPZ	600	T
11	2511	J52	25	1,15	1,20	*112MB-6	1800	3,32	95	315	2SPZ	567	T
12	2329	J52	25	1,24	1,22	132S-6	1700	3,16	95	300	2SPZ	529	N
12	2446	J52	25	1,18	1,21	132S-6	1700	3,32	95	315	2SPZ	516	N
12	2392	J52	25	1,21	1,19	*112MB-6	1700	3,16	95	300	2SPZ	529	N
12	2446	J52	25	1,18	1,25	132S-6	1900	3,32	95	315	2SPZ	617	T
12	2461	J52	15	1,18	1,18	132M-8	2120	4,02	112	450	2SPZ	594	T
12	2392	J52	25	1,21	1,21	*112MB-6	1800	3,16	95	300	2SPZ	580	T
13	2174	J52	25	1,33	1,23	132S-6	1700	2,95	95	280	2SPZ	547	N
13	2126	J32	25	1,04	1,21	132S-6	1600	2,95	95	280	2SPZ	496	N
13	2196	J32	15	1,00	1,13	132M-8	1800	3,57	112	400	2SPZ	475	N
13	2232	J52	25	1,30	1,18	*112MB-6	1600	2,95	95	280	2SPZ	496	N
13	2174	J52	25	1,33	1,25	132S-6	1800	2,95	95	280	2SPZ	598	T
13	2196	J32	15	1,00	1,16	132M-8	1900	3,57	112	400	2SPZ	527	T
13	2183	J32	25	1,01	1,18	*112MB-6	1600	2,95	95	280	2SPZ	496	T
13	2219	J52	25	1,31	1,00	100LB-4	2120	4,48	106	475	1SPZ	573	T
14	2055	J52	15	1,41	1,18	132S-6	1900	4,47	95	425	2SPZ	514	N
14	2059	J32	15	1,07	1,15	132M-8	1800	3,35	112	375	2SPZ	499	N
14	2113	J52	25	1,37	1,19	*112MB-6	1600	2,79	95	265	2SPZ	509	N
14	2066	J32	25	1,07	1,17	*112MB-6	1500	2,79	95	265	2SPZ	459	N
14	2110	J52	15	1,37	1,15	*112MB-6	1900	4,47	95	425	2SPZ	514	N
14	1993	J52	25	1,45	1,20	*112MB-6	1600	2,63	95	250	2SPZ	523	N
14	2058	J52	25	1,41	1,25	132S-6	1800	2,79	95	265	2SPZ	611	T

*High efficiency motor

SERIES J

POWER RATINGS V-BELT TRANSMISSIONS

3.00 kW

n2 rpm	T2 Nm	Gear unit	i	fbp SF	V-belt length SF	Motor	V-belt length mm	Pulley Ratio	Pulley D1	Pulley D2	Pulley type	C-C mm	Motor- mount type
14	1993	J52	25	1,45	1,21	*112MB-6	1700	2,63	95	250	2SPZ	573	T
14	1986	J52	15	1,46	1,19	*112MB-6	2000	4,21	95	400	2SPZ	591	T
14	2066	J32	25	1,07	1,19	*112MB-6	1600	2,79	95	265	2SPZ	509	T
14	1994	J32	15	1,10	1,14	*112MB-6	1800	4,21	95	400	2SPZ	487	T
14	2050	J52	15	1,41	1,20	132M-8	2000	3,35	112	375	2SPZ	602	T
14	1985	J52	25	1,46	1,00	100LB-4	2000	4,01	106	425	1SPZ	559	T
15	1941	J52	25	1,49	1,22	132S-6	1600	2,63	95	250	2SPZ	523	N
15	1942	J32	15	1,13	1,17	132S-6	1800	4,21	95	400	2SPZ	487	N
15	1949	J32	25	1,13	1,17	*112MB-6	1500	2,63	95	250	2SPZ	472	N
15	1861	J52	15	1,56	1,16	*112MB-6	1800	3,95	95	375	2SPZ	511	N
15	1869	J32	15	1,18	1,14	*112MB-6	1700	3,95	95	375	2SPZ	459	N
15	1934	J52	15	1,50	1,20	132S-6	1900	4,21	95	400	2SPZ	539	N
15	1898	J32	25	1,16	1,20	132S-6	1500	2,63	95	250	2SPZ	472	N
15	1934	J52	15	1,50	1,22	132S-6	2000	4,21	95	400	2SPZ	591	T
15	1898	J32	25	1,16	1,22	132S-6	1600	2,63	95	250	2SPZ	523	T
15	1869	J52	25	1,55	1,02	100LB-4	2000	3,77	106	400	1SPZ	583	T
15	1881	J52	25	1,54	1,22	*112MB-6	1700	2,48	95	236	2SPZ	585	T
15	1861	J52	15	1,56	1,19	*112MB-6	1900	3,95	95	375	2SPZ	563	T
15	1869	J32	15	1,18	1,16	*112MB-6	1800	3,95	95	375	2SPZ	511	T
16	1739	J52	25	1,67	1,24	132S-6	1600	2,36	95	224	2SPZ	545	N
16	1832	J52	25	1,58	1,23	132S-6	1600	2,48	95	236	2SPZ	535	N
16	1792	J32	25	1,23	1,21	132S-6	1500	2,48	95	236	2SPZ	484	N
16	1786	J52	25	1,62	1,19	*112MB-6	1500	2,36	95	224	2SPZ	495	N
16	1770	J32	15	1,24	1,15	*112MB-6	1700	3,74	95	355	2SPZ	478	N
16	1739	J52	25	1,67	1,25	132S-6	1700	2,36	95	224	2SPZ	595	T
16	1832	J52	25	1,58	1,25	132S-6	1700	2,48	95	236	2SPZ	585	T
16	1813	J52	15	1,60	1,24	132S-6	2000	3,95	95	375	2SPZ	614	T
16	1792	J32	25	1,23	1,23	132S-6	1600	2,48	95	236	2SPZ	535	T
16	1821	J32	15	1,21	1,19	132S-6	1800	3,95	95	375	2SPZ	511	T
16	1752	J52	25	1,66	1,01	100LB-4	1900	3,54	106	375	1SPZ	555	T
16	1786	J52	25	1,62	1,23	*112MB-6	1700	2,36	95	224	2SPZ	595	T
16	1746	J32	25	1,26	1,19	*112MB-6	1500	2,36	95	224	2SPZ	495	T
16	1840	J32	25	1,20	1,18	*112MB-6	1500	2,48	95	236	2SPZ	484	T
16	1762	J52	15	1,65	1,20	*112MB-6	1900	3,74	95	355	2SPZ	581	T
17	1701	J52	15	1,29	1,22	132S-6	1500	2,36	95	224	2SPZ	495	N
17	1716	J52	15	1,69	1,21	132S-6	1800	3,74	95	355	2SPZ	530	N
17	1724	J32	15	1,28	1,18	132S-6	1700	3,74	95	355	2SPZ	478	N
17	1690	J52	25	1,72	1,19	*112MB-6	1500	2,23	95	212	2SPZ	505	N
17	1663	J52	15	1,74	1,17	*112MB-6	1700	3,53	95	335	2SPZ	497	N
17	1653	J32	25	1,33	1,17	*112MB-6	1400	2,23	95	212	2SPZ	454	N
17	1646	J52	25	1,76	1,26	132S-6	1700	2,23	95	212	2SPZ	605	T
17	1724	J32	15	1,28	1,21	132S-6	1800	3,74	95	355	2SPZ	530	T
17	1658	J52	25	1,75	1,02	100LB-4	1900	3,35	106	355	1SPZ	574	T
17	1653	J32	25	1,33	1,19	*112MB-6	1500	2,23	95	212	2SPZ	505	T
17	1670	J32	15	1,32	1,17	*112MB-6	1700	3,53	95	335	2SPZ	497	T
18	1620	J52	15	1,79	1,22	132S-6	1800	3,53	95	335	2SPZ	548	N
18	1626	J32	15	1,35	1,19	132S-6	1700	3,53	95	335	2SPZ	497	N
18	1559	J32	25	1,41	1,18	*112MB-6	1400	2,11	95	200	2SPZ	465	N
18	1570	J32	25	1,40	1,16	*112MB-6	1600	3,32	95	315	2SPZ	464	N
18	1620	J52	15	1,79	1,24	132S-6	1900	3,53	95	335	2SPZ	600	T
18	1609	J52	15	1,37	1,22	132S-6	1500	2,23	95	212	2SPZ	505	T
18	1570	J32	15	1,40	1,18	*112MB-6	1700	3,32	95	315	2SPZ	516	T
18	1559	J32	25	1,41	1,20	*112MB-6	1500	2,11	95	200	2SPZ	515	T
19	1481	J32	25	1,46	1,18	*112MB-6	1400	2,00	95	190	2SPZ	473	N
19	1495	J32	15	1,47	1,17	*112MB-6	1600	3,16	95	300	2SPZ	478	N
19	1518	J32	25	1,44	1,23	132S-6	1500	2,11	95	200	2SPZ	515	T
19	1529	J32	15	1,44	1,21	132S-6	1700	3,32	95	315	2SPZ	516	T
19	1506	J22	15	1,00	1,18	132S-6	1600	3,32	95	315	2SP	464	T
19	1494	J22	25	1,00	1,17	*112MB-6	1320	2,00	95	190	2SPZ	433	T
20	1442	J32	25	1,50	1,21	132S-6	1400	2,00	95	190	2SPZ	473	N
20	1456	J32	15	1,51	1,19	132S-6	1600	3,16	95	300	2SPZ	478	N
20	1403	J32	25	1,53	1,19	*112MB-6	1400	1,89	95	180	2SPZ	481	N

*High
efficiency
motor

SERIES J

POWER RATINGS V-BELT TRANSMISSIONS

3.00 kW

n2 rpm	T2 Nm	Gear unit	i	fbp SF	V-belt length SF	Motor	V-belt length mm	Pulley Ratio	Pulley D1	Pulley D2	Pulley type	C-C mm	Motor- mount type
20	1442	J32	25	1,50	1,23	132S-6	1500	2,00	95	190	2SPZ	523	T
20	1456	J32	15	1,51	1,22	132S-6	1700	3,16	95	300	2SPZ	529	T
20	1455	J22	25	1,03	1,21	132S-6	1400	2,00	95	190	2SPZ	473	T
20	1434	J22	15	1,05	1,19	132S-6	1600	3,16	95	300	2SPZ	478	T
20	1415	J22	25	1,06	1,17	*112MB-6	1320	1,89	95	180	2SPZ	441	T
21	1367	J32	25	1,55	1,22	132S-6	1400	1,89	95	180	2SPZ	481	N
21	1359	J32	15	1,62	1,21	132S-6	1600	2,95	95	280	2SPZ	496	N
21	1333	J32	25	1,58	1,28	*112MB-6	1400	1,80	100	180	2SPZ	478	N
21	1367	J32	25	1,55	1,24	132S-6	1500	1,89	95	180	2SPZ	532	T
21	1378	J22	25	1,08	1,22	132S-6	1400	1,89	95	180	2SPZ	481	T
21	1396	J32	15	1,58	1,18	*112MB-6	1600	2,95	95	280	2SPZ	496	T
21	1337	J22	25	1,10	1,18	*112MB-6	1320	1,79	95	170	2SPZ	450	T
21	1374	J22	15	1,09	1,16	*112MB-6	1500	2,95	95	280	2SPZ	445	T
22	1298	J32	25	1,61	1,31	132S-6	1400	1,80	100	180	2SPZ	478	N
22	1321	J32	15	1,67	1,17	*112MB-6	1500	2,79	95	265	2SPZ	459	N
22	1298	J32	25	1,61	1,33	132S-6	1500	1,80	100	180	2SPZ	528	T
22	1287	J32	15	1,71	1,22	132S-6	1600	2,79	95	265	2SPZ	509	T
22	1321	J32	15	1,67	1,19	*112MB-6	1600	2,79	95	265	2SPZ	509	T
22	1301	J22	15	1,15	1,17	*112MB-6	1500	2,79	95	265	2SPZ	459	T
22	1279	J22	15	1,63	1,00	100LB-4	1600	2,64	106	280	1SPZx	488	T
23	1257	J22	15	1,65	1,38	*112MB-6	1400	1,70	106	180	2SPZ	473	N
23	1246	J32	15	1,77	1,17	*112MB-6	1500	2,63	95	250	2SPZ	472	N
23	1225	J22	25	1,17	1,21	132S-6	1320	1,68	95	160	2SPZ	458	T
23	1267	J22	15	1,19	1,19	132S-6	1500	2,79	95	265	2SPZ	459	T
23	1258	J22	25	1,15	1,18	*112MB-6	1320	1,68	95	160	2SPZ	458	T
24	1210	J32	25	1,69	1,01	100LB-4	1600	2,50	106	265	1SPZ	502	T
24	1195	J22	25	1,19	1,27	*112MB-6	1320	1,60	100	160	2SPZ	454	T
24	1195	J22	15	1,26	1,20	132S-6	1500	2,63	95	250	2SPZ	472	T
25	1142	J32	25	1,76	1,00	100LB-4	1500	2,36	106	250	1SPZ	464	N
25	1128	J22	15	1,33	1,21	132S-6	1500	2,48	95	236	2SPZ	484	T
25	1158	J22	15	1,29	1,16	*112MB-6	1400	2,48	95	236	2SPZ	434	T
26	1099	J22	15	1,36	1,17	*112MB-6	1400	2,36	95	224	2SPZ	444	T
28	1041	J22	15	1,44	1,17	*112MB-6	1400	2,23	95	212	2SPZ	454	T
28	1013	J22	15	1,48	1,20	132S-6	1400	2,23	95	212	2SPZ	454	T
29	982	J22	15	1,53	1,18	*112MB-6	1400	2,11	95	200	2SPZ	465	T
29	977	J22	25	1,37	1,00	100LB-4	1400	2,00	106	212	1SPZ	446	T
30	956	J22	15	1,57	1,21	132S-6	1400	2,11	95	200	2SPZ	465	T
31	933	J22	15	1,61	1,17	*112MB-6	1320	2,00	95	190	2SPZ	433	T
32	908	J22	15	1,65	1,21	132S-6	1400	2,00	95	190	2SPZ	473	T
32	883	J22	15	1,70	1,17	*112MB-6	1320	1,89	95	180	2SPZ	441	T
33	860	J22	15	1,74	1,22	132S-6	1400	1,89	95	180	2SPZ	481	T
34	834	J22	15	1,80	1,18	*112MB-6	1320	1,79	95	170	2SPZ	450	T
35	829	J22	25	1,54	1,00	100LB-4	1320	1,70	106	180	1SPZ	433	T
37	779	J12	15	1,03	1,16	*112MB-6	1250	1,68	95	160	2SPZ	423	T
37	783	J22	25	1,60	1,00	100LB-4	1320	1,60	106	170	1SPZ	441	T
39	730	J12	15	1,10	1,17	*112MB-6	1250	1,58	95	150	2SPZ	431	T
39	737	J22	25	1,67	1,00	100LB-4	1320	1,51	106	160	1SPZ	450	T
41	698	J22	25	1,73	1,08	100LB-4	1320	1,43	112	160	1SPZ	445	T
42	681	J12	15	1,17	1,17	*112MB-6	1250	1,47	95	140	2SPZ	439	T
43	662	J22	25	1,80	1,16	100LB-4	1320	1,36	118	160	1SPZ	440	T
44	647	J12	15	1,24	1,26	*112MB-6	1250	1,40	100	140	2SPZ	435	T
25	466	J12	25	1,28	1,07	100LB-4	1250	1,25	112	140	1SPZ	426	T
47	611	J12	15	1,31	1,36	*112MB-6	1250	1,32	106	140	2SPZ	431	T
48	593	J12	25	1,35	1,14	100LB-4	1250	1,19	118	140	1SPZ	422	T
51	560	J12	25	1,43	1,22	100LB-4	1250	1,12	125	140	1SPZ	416	T
54	530	J12	25	1,51	1,31	100LB-4	1250	1,06	132	140	1SPZ	411	T
57	500	J12	25	1,60	1,38	100LB-4	1250	1,00	140	140	1SPZ	404	T
62	460	J12	25	1,71	1,08	100L-2	1180	1,87	75	140	1SPZ	419	T
66	432	J12	25	1,79	1,20	100L-2	1180	1,75	80	140	1SPZ	415	T
232	124	J11	5	1,74	1,05	100LB-4	1180	1,25	112	140	1SPZ	391	T
244	117	J11	5	1,80	1,13	100LB-4	1180	1,19	118	140	1SPZ	387	T

*High
efficiency
motor

SERIES J

POWER RATINGS V-BELT TRANSMISSIONS

4.00 kW

n2 rpm	T2 Nm	Gear unit	i	fbp SF	V-belt length SF	Motor	V-belt length mm	Pulley Ratio	Pulley D1	Pulley D2	Pulley type	C-C mm	Motor- mount type
20	1442	J32	25	1,50	1,23	132S-6	1500	2,00	95	190	2SPZ	523	T
20	1456	J32	15	1,51	1,22	132S-6	1700	3,16	95	300	2SPZ	529	T
20	1455	J22	25	1,03	1,21	132S-6	1400	2,00	95	190	2SPZ	473	T
20	1434	J22	15	1,05	1,19	132S-6	1600	3,16	95	300	2SPZ	478	T
20	1415	J22	25	1,06	1,17	*112MB-6	1320	1,89	95	180	2SPZ	441	T
21	1367	J32	25	1,55	1,22	132S-6	1400	1,89	95	180	2SPZ	481	N
21	1359	J32	15	1,62	1,21	132S-6	1600	2,95	95	280	2SPZ	496	N
21	1333	J32	25	1,58	1,28	*112MB-6	1400	1,80	100	180	2SPZ	478	N
21	1367	J32	25	1,55	1,24	132S-6	1500	1,89	95	180	2SPZ	532	T
21	1378	J22	25	1,08	1,22	132S-6	1400	1,89	95	180	2SPZ	481	T
21	1396	J32	15	1,58	1,18	*112MB-6	1600	2,95	95	280	2SPZ	496	T
21	1337	J22	25	1,10	1,18	*112MB-6	1320	1,79	95	170	2SPZ	450	T
21	1374	J22	15	1,09	1,16	*112MB-6	1500	2,95	95	280	2SPZ	445	T
22	1298	J32	25	1,61	1,31	132S-6	1400	1,80	100	180	2SPZ	478	N
22	1321	J32	15	1,67	1,17	*112MB-6	1500	2,79	95	265	2SPZ	459	N
22	1298	J32	25	1,61	1,33	132S-6	1500	1,80	100	180	2SPZ	528	T
22	1287	J32	15	1,71	1,22	132S-6	1600	2,79	95	265	2SPZ	509	T
22	1321	J32	15	1,67	1,19	*112MB-6	1600	2,79	95	265	2SPZ	509	T
22	1301	J22	15	1,15	1,17	*112MB-6	1500	2,79	95	265	2SPZ	459	T
22	1279	J22	15	1,63	1,00	100LB-4	1600	2,64	106	280	1SPZx	488	T
23	1257	J22	15	1,65	1,38	*112MB-6	1400	1,70	106	180	2SPZ	473	N
23	1246	J32	15	1,77	1,17	*112MB-6	1500	2,63	95	250	2SPZ	472	N
23	1225	J22	25	1,17	1,21	132S-6	1320	1,68	95	160	2SPZ	458	T
23	1267	J22	15	1,19	1,19	132S-6	1500	2,79	95	265	2SPZ	459	T
23	1258	J22	25	1,15	1,18	*112MB-6	1320	1,68	95	160	2SPZ	458	T
24	1210	J32	25	1,69	1,01	100LB-4	1600	2,50	106	265	1SPZ	502	T
24	1195	J22	25	1,19	1,27	*112MB-6	1320	1,60	100	160	2SPZ	454	T
24	1195	J22	15	1,26	1,20	132S-6	1500	2,63	95	250	2SPZ	472	T
25	1142	J32	25	1,76	1,00	100LB-4	1500	2,36	106	250	1SPZ	464	N
25	1128	J22	15	1,33	1,21	132S-6	1500	2,48	95	236	2SPZ	484	T
25	1158	J22	15	1,29	1,16	*112MB-6	1400	2,48	95	236	2SPZ	434	T
26	1099	J22	15	1,36	1,17	*112MB-6	1400	2,36	95	224	2SPZ	444	T
28	1041	J22	15	1,44	1,17	*112MB-6	1400	2,23	95	212	2SPZ	454	T
28	1013	J22	15	1,48	1,20	132S-6	1400	2,23	95	212	2SPZ	454	T
29	982	J22	15	1,53	1,18	*112MB-6	1400	2,11	95	200	2SPZ	465	T
29	977	J22	25	1,37	1,00	100LB-4	1400	2,00	106	212	1SPZ	446	T
30	956	J22	15	1,57	1,21	132S-6	1400	2,11	95	200	2SPZ	465	T
31	933	J22	15	1,61	1,17	*112MB-6	1320	2,00	95	190	2SPZ	433	T
32	908	J22	15	1,65	1,21	132S-6	1400	2,00	95	190	2SPZ	473	T
32	883	J22	15	1,70	1,17	*112MB-6	1320	1,89	95	180	2SPZ	441	T
33	860	J22	15	1,74	1,22	132S-6	1400	1,89	95	180	2SPZ	481	T
34	834	J22	15	1,80	1,18	*112MB-6	1320	1,79	95	170	2SPZ	450	T
35	829	J22	25	1,54	1,00	100LB-4	1320	1,70	106	180	1SPZ	433	T
37	779	J12	15	1,03	1,16	*112MB-6	1250	1,68	95	160	2SPZ	423	T
37	783	J22	25	1,60	1,00	100LB-4	1320	1,60	106	170	1SPZ	441	T
39	730	J12	15	1,10	1,17	*112MB-6	1250	1,58	95	150	2SPZ	431	T
39	737	J22	25	1,67	1,00	100LB-4	1320	1,51	106	160	1SPZ	450	T
41	698	J22	25	1,73	1,08	100LB-4	1320	1,43	112	160	1SPZ	445	T
42	681	J12	15	1,17	1,17	*112MB-6	1250	1,47	95	140	2SPZ	439	T
43	662	J22	25	1,80	1,16	100LB-4	1320	1,36	118	160	1SPZ	440	T
44	647	J12	15	1,24	1,26	*112MB-6	1250	1,40	100	140	2SPZ	435	T
25	466	J12	25	1,28	1,07	100LB-4	1250	1,25	112	140	1SPZ	426	T
47	611	J12	15	1,31	1,36	*112MB-6	1250	1,32	106	140	2SPZ	431	T
48	593	J12	25	1,35	1,14	100LB-4	1250	1,19	118	140	1SPZ	422	T
51	560	J12	25	1,43	1,22	100LB-4	1250	1,12	125	140	1SPZ	416	T
54	530	J12	25	1,51	1,31	100LB-4	1250	1,06	132	140	1SPZ	411	T
57	500	J12	25	1,60	1,38	100LB-4	1250	1,00	140	140	1SPZ	404	T
62	460	J12	25	1,71	1,08	100L-2	1180	1,87	75	140	1SPZ	419	T
66	432	J12	25	1,79	1,20	100L-2	1180	1,75	80	140	1SPZ	415	T
232	124	J11	5	1,74	1,05	100LB-4	1180	1,25	112	140	1SPZ	391	T
244	117	J11	5	1,80	1,13	100LB-4	1180	1,19	118	140	1SPZ	387	T

*High efficiency motor

SERIES J

POWER RATINGS V-BELT TRANSMISSIONS

4.00 kW

n2 rpm	T2 Nm	Gear unit	i	fbp SF	V-belt length SF	Motor	V-belt length mm	Pulley Ratio	Pulley D1	Pulley D2	Pulley type	C-C mm	Motor- mount type
23	1631	J32	25	1,26	1,35	132MA-6	1600	1,70	125	212	2SPZ	533	T
23	1648	J32	15	1,34	1,32	132MA-6	1800	2,68	125	335	2SPZ	527	T
23	1670	J52	25	1,74	1,03	112M-4	1900	2,54	132	335	1SPZ	573	T
23	1687	J52	25	1,72	1,02	*100LC-4	1900	2,54	132	335	1SPZ	573	T
25	1550	J32	15	1,42	1,31	132MA-6	1700	2,52	125	315	2SPZ	495	N
25	1535	J32	25	1,31	1,01	112M-4	1700	2,39	132	315	1SPZ	490	T
26	1462	J32	25	1,36	1,00	112M-4	1600	2,27	132	300	1SPZ	452	N
26	1476	J32	15	1,48	1,32	132MA-6	1700	2,40	125	300	2SPZ	508	T
26	1462	J32	25	1,36	1,02	112M-4	1700	2,27	132	300	1SPZ	503	T
26	1478	J32	25	1,35	1,01	*100LC-4	1700	2,27	132	300	1SPZ	503	T
26	1453	J22	15	1,03	1,30	132MA-6	1600	2,40	125	300	2SPZ	457	T
28	1378	J32	15	1,55	1,31	132MA-6	1600	2,24	125	280	2SPZ	475	N
28	1365	J32	25	1,43	1,01	112M-4	1600	2,12	132	280	1SPZ	470	N
28	1378	J32	15	1,55	1,33	132MA-6	1700	2,24	125	280	2SPZ	525	T
28	1356	J22	15	1,11	1,31	132MA-6	1600	2,24	125	280	2SPZ	475	T
29	1304	J32	15	1,62	1,32	132MA-6	1600	2,12	125	265	2SPZ	488	N
29	1305	J32	25	1,47	1,01	*100LC-4	1600	2,01	132	265	1SPZ	483	T
29	1303	J32	25	1,03	1,00	112M-4	1500	2,01	132	265	1SPZ	432	T
30	1292	J32	25	1,48	1,02	112M-4	1600	2,01	132	265	1SPZ	483	T
31	1230	J32	15	1,68	1,33	132MA-6	1600	2,00	125	250	2SPZ	501	N
31	1218	J32	25	1,54	1,02	112M-4	1600	1,89	132	250	1SPZ	496	T
31	1231	J32	25	1,53	1,01	*100LC-4	1600	1,89	132	250	1SPZ	496	T
31	1247	J32	15	1,67	1,00	112M-4	1900	3,03	132	400	1SPZ	514	T
31	1229	J22	25	1,07	1,00	112M-4	1500	1,89	132	250	1SPZ	445	T
33	1150	J32	25	1,61	1,01	112M-4	1500	1,79	132	236	1SPZ	457	N
33	1161	J32	15	1,75	1,34	132MA-6	1600	1,89	125	236	2SPZ	513	T
33	1143	J22	15	1,31	1,32	132MA-6	1500	1,89	125	236	2SPZ	462	T
33	1150	J32	25	1,61	1,03	112M-4	1600	1,79	132	236	1SPZ	508	T
33	1160	J22	25	1,11	1,01	112M-4	1500	1,79	132	236	1SPZ	457	T
35	1092	J32	25	1,67	1,02	112M-4	1500	1,70	132	224	1SPZ	467	N
35	1103	J32	25	1,66	1,01	*100LC-4	1500	1,70	132	224	1SPZ	467	N
35	1085	J22	15	1,38	1,32	132MA-6	1500	1,79	125	224	2SPZ	473	T
37	1033	J32	25	1,73	1,02	112M-4	1500	1,61	132	212	1SPZ	477	N
37	1027	J22	15	1,46	1,33	132MA-6	1500	1,70	125	212	2SPZ	483	T
37	1044	J32	25	1,72	1,01	*100LC-4	1500	1,61	132	212	1SPZ	477	T
39	983	J22	25	1,25	1,01	112M-4	1400	1,52	132	200	1SPZ	437	T
39	985	J32	25	1,79	1,01	*100LC-4	1500	1,52	132	200	1SPZ	487	T
41	934	J22	25	1,30	1,01	112M-4	1400	1,44	132	190	1SPZ	445	T
41	921	J22	15	1,63	1,00	112M-4	1600	2,27	132	300	1SPZ	452	T
42	920	J22	15	1,63	1,32	132MA-6	1400	1,52	125	190	2SPZ	451	T
43	885	J22	25	1,35	1,01	112M-4	1400	1,36	132	180	1SPZ	454	T
44	872	J22	15	1,72	1,32	132MA-6	1400	1,44	125	180	2SPZ	459	T
46	836	J22	25	1,40	1,01	112M-4	1400	1,29	132	170	1SPZ	462	T
51	749	J22	25	1,51	1,06	*100LC-4	1320	1,14	140	160	1SPZ	424	T
51	755	J12	25	1,06	1,00	112M-4	1320	1,14	132	150	1SPZ	438	T
52	742	J22	25	1,52	1,09	112M-4	1400	1,14	140	160	1SPZ	464	T
55	692	J22	25	1,60	1,18	112M-4	1400	1,07	150	160	1SPZ	456	T
82	566	J12	15	1,17	1,00	112M-4	1400	1,70	132	224	1SPZ	417	T
57	664	J12	25	1,20	1,05	112M-4	1320	1,00	140	140	1SPZ	439	T
57	672	J12	25	1,19	1,03	*100LC-4	1250	1,00	140	140	1SPZ	404	T
58	656	J22	25	1,66	1,24	*100LC-4	1400	1,00	160	160	1SPZ	448	T
59	649	J22	25	1,67	1,25	112M-4	1400	1,00	160	160	1SPZ	448	T
59	645	J12	15	1,24	1,00	112M-4	1400	1,61	132	212	1SPZ	427	T
63	609	J12	15	1,32	1,01	112M-4	1400	1,52	132	200	1SPZ	437	T
70	548	J12	15	1,46	1,00	112M-4	1320	1,36	132	180	1SPZ	414	T
73	520	J12	25	1,43	1,06	112M-2	1180	1,56	90	140	1SPZ	408	T
74	517	J12	15	1,55	1,00	112M-4	1320	1,29	132	170	1SPZ	422	T
75	511	J12	25	1,44	1,08	*100LB-2	1180	1,56	90	140	1SPZ	408	T
77	493	J12	25	1,47	1,16	112M-2	1250	1,47	95	140	1SPZ	439	T
78	487	J12	15	1,64	1,00	112M-4	1320	1,21	132	160	1SPZ	430	T
79	485	J12	25	1,49	1,16	*100LB-2	1180	1,47	95	140	1SPZ	404	T
82	468	J12	25	1,52	1,25	112M-2	1250	1,40	100	140	1SPZ	435	T
83	460	J12	25	1,54	1,25	*100LB-2	1180	1,40	100	140	1SPZ	400	T

*High
efficiency
motor

SERIES J

POWER RATINGS V-BELT TRANSMISSIONS

4.00 kW

5.50 kW

n2 rpm	T2 Nm	Gear unit	i	fbp SF	V-belt length SF	Motor	V-belt length mm	Pulley Ratio	Pulley D1	Pulley D2	Pulley type	C-C mm	Motor- mount type
84	456	J12	15	1,74	1,00	112M-4	1320	1,14	132	150	1SPZ	438	T
86	442	J12	25	1,58	1,35	112M-2	1250	1,32	106	140	1SPZ	431	T
88	434	J12	25	1,60	1,35	*100LB-2	1180	1,32	106	140	1SPZ	396	T
288	133	J11	5	1,51	1,03	*100LC-4	1250	1,00	140	140	1SPZ	404	T
7	7052	J100	25	1,42	1,08	160M-8	2500	3,81	118	450	3SPZ	786	T
8	6660	J100	25	1,50	1,09	160M-8	2500	3,60	118	425	3SPZ	808	T
12	4350	J72	15	1,15	1,39	160M-8	2360	4,03	118	475	4SPZ	690	T
12	4350	J72	15	1,15	1,05	160M-8	2360	4,03	118	475	3SPZ	690	T
13	4121	J72	15	1,21	1,06	160M-8	2360	3,81	118	450	3SPZ	714	T
14	3818	J72	25	1,31	1,00	132MB-6	2120	2,84	125	355	2SPZ	672	T
16	3226	J72	25	1,55	1,00	132MB-6	2000	2,40	125	300	2SPZ	660	T
17	3011	J72	25	1,66	1,01	132MB-6	2000	2,24	125	280	2SPZ	677	T
18	2851	J72	25	1,75	1,08	132MB-6	2000	2,12	132	280	2SPZ	672	T
24	2158	J32	15	1,02	1,37	*112MB-4	2000	3,79	132	500	2SPZ	466	N
25	2121	J32	15	1,03	1,39	132S-4	2000	3,79	132	500	2SPZ	466	N
26	2018	J52	25	1,44	1,31	132SA-2	1800	4,44	80	355	2SPZ	540	N
26	2018	J52	25	1,44	1,34	132SA-2	1900	4,44	80	355	2SPZ	592	T
26	2018	J52	25	1,44	1,34	*112MB-2	1900	4,44	80	355	2SPZ	592	T
26	2050	J32	15	1,07	1,40	*112MB-4	2000	3,60	132	475	2SPZ	493	T
27	1973	J32	25	1,00	1,29	132SA-2	1700	4,44	80	355	2SPZ	488	N
27	1942	J32	15	1,11	1,40	*112MB-4	1900	3,41	132	450	2SPZ	465	N
27	1973	J32	25	1,00	1,29	*112MB-2	1700	4,44	80	355	2SPZ	488	T
28	1862	J32	25	1,04	1,27	*112MB-2	1600	4,19	80	335	2SPZ	455	N
28	1904	J52	25	1,52	1,30	*112MB-2	1700	4,19	80	335	2SPZ	507	N
28	1904	J52	25	1,52	1,35	132SA-2	1900	4,19	80	335	2SPZ	610	T
28	1862	J32	25	1,04	1,30	132SA-2	1700	4,19	80	335	2SPZ	507	T
28	1862	J32	25	1,04	1,30	*112MB-2	1700	4,19	80	335	2SPZ	507	T
29	1791	J52	25	1,62	1,32	132SA-2	1700	3,94	80	315	2SPZ	526	N
29	1791	J52	25	1,62	1,32	*112MB-2	1700	3,94	80	315	2SPZ	526	N
29	1791	J52	25	1,62	1,34	*112MB-2	1800	3,94	80	315	2SPZ	577	T
30	1751	J32	25	1,09	1,29	132SA-2	1600	3,94	80	315	2SPZ	474	N
30	1751	J32	25	1,09	1,29	*112MB-2	1600	3,94	80	315	2SPZ	474	N
30	1751	J32	25	1,09	1,32	132SA-2	1700	3,94	80	315	2SPZ	526	T
31	1705	J52	25	1,70	1,33	132SA-2	1700	3,75	80	300	2SPZ	540	N
31	1705	J52	25	1,70	1,35	132SA-2	1800	3,75	80	300	2SPZ	591	T
31	1705	J52	25	1,70	1,35	*112MB-2	1800	3,75	80	300	2SPZ	591	T
32	1667	J32	25	1,13	1,30	132SA-2	1600	3,75	80	300	2SPZ	488	N
32	1667	J32	25	1,13	1,30	*112MB-2	1600	3,75	80	300	2SPZ	488	T
34	1556	J32	25	1,18	1,29	*112MB-2	1500	3,50	80	280	2SPZ	456	N
34	1556	J32	25	1,18	1,32	132SA-2	1600	3,50	80	280	2SPZ	507	T
34	1556	J32	25	1,18	1,32	*112MB-2	1600	3,50	80	280	2SPZ	507	T
36	1473	J32	25	1,23	1,30	132SA-2	1500	3,31	80	265	2SPZ	469	N
36	1473	J32	25	1,23	1,30	*112MB-2	1500	3,31	80	265	2SPZ	469	N
36	1473	J32	25	1,23	1,33	132SA-2	1600	3,31	80	265	2SPZ	520	T
38	1389	J32	25	1,28	1,31	132SA-2	1500	3,13	80	250	2SPZ	483	N
38	1389	J32	25	1,28	1,33	132SA-2	1600	3,13	80	250	2SPZ	533	T
38	1389	J32	25	1,28	1,31	*112MB-2	1500	3,13	80	250	2SPZ	483	T
40	1312	J32	25	1,33	1,32	132SA-2	1500	2,95	80	236	2SPZ	495	N
40	1312	J32	25	1,33	1,32	*112MB-2	1500	2,95	80	236	2SPZ	495	T
42	1245	J32	25	1,38	1,30	*112MB-2	1400	2,80	80	224	2SPZ	455	N
42	1245	J32	25	1,38	1,33	132SA-2	1500	2,80	80	224	2SPZ	505	T
42	1245	J32	25	1,38	1,33	*112MB-2	1500	2,80	80	224	2SPZ	505	T
42	1242	J22	15	1,21	1,25	*112MB-2	1600	4,44	80	355	2SPZ	436	T
44	1191	J32	15	1,56	1,27	*112MB-2	1600	4,19	80	335	2SPZ	455	N
44	1188	J22	25	1,00	1,31	132SA-2	1400	2,65	80	212	2SPZ	465	T
44	1188	J22	25	1,00	1,31	*112MB-2	1400	2,65	80	212	2SPZ	465	T
44	1191	J32	15	1,56	1,30	132SA-2	1700	4,19	80	335	2SPZ	507	T
44	1191	J32	15	1,56	1,30	*112MB-2	1700	4,19	80	335	2SPZ	507	T
45	1178	J32	25	1,44	1,31	*112MB-2	1400	2,65	80	212	2SPZ	465	N
45	1178	J32	25	1,44	1,33	132SA-2	1500	2,65	80	212	2SPZ	516	T
45	1172	J22	15	1,28	1,27	132SA-2	1600	4,19	80	335	2SPZ	455	T

*High efficiency motor

SERIES J

POWER RATINGS V-BELT TRANSMISSIONS

5.50 kW

n2 rpm	T2 Nm	Gear unit	i	fbp SF	V-belt length SF	Motor	V-belt length mm	Pulley Ratio	Pulley D1	Pulley D2	Pulley type	C-C mm	Motor- mount type
45	1159	J32	15	1,59	1,04	132MB-6	1500	1,36	132	180	2SPZ	504	T
45	1178	J32	25	1,44	1,33	*112MB-2	1500	2,65	80	212	2SPZ	516	T
45	1172	J22	15	1,28	1,27	*112MB-2	1600	4,19	80	335	2SPZ	455	T
47	1112	J32	25	1,50	1,32	132SA-2	1400	2,50	80	200	2SPZ	476	N
47	1120	J32	15	1,63	1,29	132SA-2	1600	3,94	80	315	2SPZ	474	N
47	1112	J32	25	1,50	1,32	*112MB-2	1400	2,50	80	200	2SPZ	476	N
47	1120	J32	15	1,63	1,29	*112MB-2	1600	3,94	80	315	2SPZ	474	N
47	1112	J32	25	1,50	1,34	132SA-2	1500	2,50	80	200	2SPZ	526	T
47	1120	J32	15	1,63	1,32	132SA-2	1700	3,94	80	315	2SPZ	526	T
47	1121	J22	25	1,04	1,32	132SA-2	1400	2,50	80	200	2SPZ	476	T
47	1121	J22	25	1,04	1,30	*112MB-2	1320	2,50	80	200	2SPZ	435	T
48	1093	J32	15	1,66	1,12	132MB-6	1500	1,29	140	180	2SPZ	498	N
48	1102	J22	15	1,36	1,29	132SA-2	1600	3,94	80	315	2SPZ	474	T
49	1066	J32	15	1,69	1,30	132SA-2	1600	3,75	80	300	2SPZ	488	N
49	1065	J22	25	1,08	1,32	132SA-2	1400	2,38	80	190	2SPZ	484	T
49	1066	J32	15	1,69	1,30	*112MB-2	1600	3,75	80	300	2SPZ	488	T
49	1065	J22	25	1,08	1,30	*112MB-2	1320	2,38	80	190	2SPZ	444	T
50	1056	J32	25	1,55	1,32	132SA-2	1400	2,38	80	190	2SPZ	484	N
50	1056	J32	25	1,55	1,34	132SA-2	1500	2,38	80	190	2SPZ	534	T
50	1056	J32	25	1,55	1,32	*112MB-2	1400	2,38	80	190	2SPZ	484	T
50	1050	J22	15	1,43	1,27	*112MB-2	1500	3,75	80	300	2SPZ	437	T
51	1020	J32	15	1,74	1,21	132MB-6	1500	1,20	150	180	2SPZ	490	N
52	1009	J22	25	1,12	1,31	132SA-2	1320	2,25	80	180	2SPZ	452	T
52	1014	J22	15	1,46	1,02	132MB-6	1400	1,21	132	160	2SPZ	470	T
52	1009	J22	25	1,12	1,31	*112MB-2	1320	2,25	80	180	2SPZ	452	T
53	1000	J32	25	1,61	1,33	132SA-2	1400	2,25	80	180	2SPZ	493	N
53	1000	J32	25	1,61	1,31	*112MB-2	1320	2,25	80	180	2SPZ	452	N
53	995	J32	15	1,77	1,29	*112MB-2	1500	3,50	80	280	2SPZ	456	N
53	995	J32	15	1,77	1,32	132SA-2	1600	3,50	80	280	2SPZ	507	T
53	1000	J32	25	1,61	1,33	*112MB-2	1400	2,25	80	180	2SPZ	493	T
53	995	J32	15	1,77	1,32	*112MB-2	1600	3,50	80	280	2SPZ	507	T
54	980	J22	15	1,50	1,29	132SA-2	1500	3,50	80	280	2SPZ	456	T
54	980	J22	15	1,50	1,29	*112MB-2	1500	3,50	80	280	2SPZ	456	T
55	953	J22	25	1,16	1,31	132SA-2	1320	2,13	80	170	2SPZ	461	T
55	953	J22	25	1,16	1,31	*112MB-2	1320	2,13	80	170	2SPZ	461	T
55	957	J22	15	1,53	1,10	132MB-6	1400	1,14	140	160	2SPZ	464	T
57	927	J32	25	1,70	1,01	132S-4	1500	1,06	170	180	1SPZ	474	N
57	927	J32	25	1,70	1,03	132S-4	1600	1,06	170	180	1SPZ	524	T
57	927	J22	15	1,56	1,30	132SA-2	1500	3,31	80	265	2SPZ	469	T
59	891	J32	25	1,75	1,05	*112MB-4	1500	1,00	180	180	1SPZ	467	N
59	897	J22	25	1,21	1,32	132SA-2	1320	2,00	80	160	2SPZ	469	T
59	893	J22	15	1,61	1,19	132MB-6	1400	1,07	150	160	2SPZ	456	T
59	891	J32	25	1,75	1,06	*112MB-4	1600	1,00	180	180	1SPZ	517	T
59	897	J22	25	1,21	1,30	*112MB-2	1250	2,00	80	160	2SPZ	434	T
60	875	J32	25	1,77	1,07	132S-4	1500	1,00	180	180	1SPZ	467	N
60	875	J22	15	1,63	1,31	132SA-2	1500	3,13	80	250	2SPZ	483	T
60	875	J32	25	1,77	1,08	132S-4	1600	1,00	180	180	1SPZ	517	T
60	875	J22	15	1,63	1,28	*112MB-2	1400	3,13	80	250	2SPZ	432	T
64	826	J22	15	1,70	1,29	*112MB-2	1400	2,95	80	236	2SPZ	444	T
67	784	J22	15	1,76	1,30	132SA-2	1400	2,80	80	224	2SPZ	455	T
67	784	J22	15	1,76	1,30	*112MB-2	1400	2,80	80	224	2SPZ	455	T
68	777	J12	15	1,03	1,28	*112MB-2	1320	2,80	80	224	2SPZ	414	T
71	736	J12	15	1,09	1,29	*112MB-2	1320	2,65	80	212	2SPZ	425	T
75	698	J31	5	1,47	1,37	*112MB-4	2000	3,79	132	500	2SPZ	466	T
75	698	J21	5	1,55	1,33	*112MB-4	1900	3,79	132	500	2SPZ	412	T
94	766	J12	15	1,15	1,30	*112MB-2	1320	2,50	80	200	2SPZ	435	T
77	686	J31	5	1,49	1,39	132S-4	2000	3,79	132	500	2SPZ	466	N
79	663	J31	5	1,52	1,36	*112MB-4	1900	3,60	132	475	2SPZ	439	N
79	663	J21	5	1,61	1,36	*112MB-4	1900	3,60	132	475	2SPZ	439	T
79	663	J31	5	1,52	1,40	*112MB-4	2000	3,60	132	475	2SPZ	493	T
80	659	J12	15	1,21	1,28	*112MB-2	1250	2,38	80	190	2SPZ	409	T
82	641	J22	25	1,54	1,08	132SA-2	1400	1,43	112	160	1SPZ	485	T

*High
efficiency
motor

SERIES J

POWER RATINGS V-BELT TRANSMISSIONS

5.50 kW

n2 rpm	T2 Nm	Gear unit	i	fbp SF	V-belt length SF	Motor	V-belt length mm	Pulley Ratio	Pulley D1	Pulley D2	Pulley type	C-C mm	Motor- mount type
82	641	J22	25	1,54	1,07	*112MB-2	1320	1,43	112	160	1SPZ	445	T
84	628	J21	5	1,67	1,35	*112MB-4	1800	3,41	132	450	2SPZ	411	T
84	625	J12	15	1,27	1,29	*112MB-2	1250	2,25	80	180	2SPZ	417	T
84	628	J31	5	1,58	1,40	*112MB-4	1900	3,41	132	450	2SPZ	465	T
86	608	J22	25	1,59	1,15	132SA-2	1400	1,36	118	160	1SPZ	481	T
86	608	J22	25	1,59	1,14	*112MB-2	1320	1,36	118	160	1SPZ	440	T
89	593	J31	5	1,64	1,39	*112MB-4	1800	3,22	132	425	2SPZ	437	N
89	593	J21	5	1,74	1,39	*112MB-4	1800	3,22	132	425	2SPZ	437	T
89	590	J12	15	1,34	1,30	*112MB-2	1250	2,13	80	170	2SPZ	426	T
91	574	J12	25	1,19	1,05	*112MB-2	1250	1,25	112	140	1SPZ	426	T
92	574	J22	25	1,66	1,24	132SA-2	1400	1,28	125	160	1SPZ	475	T
92	574	J22	25	1,66	1,22	*112MB-2	1320	1,28	125	160	1SPZ	435	T
95	555	J12	15	1,39	1,30	*112MB-2	1250	2,00	80	160	2SPZ	434	T
96	545	J12	15	1,23	1,12	*112MB-2	1250	1,19	118	140	1SPZ	422	T
97	544	J22	25	1,72	1,32	132SA-2	1400	1,21	132	160	1SPZ	470	T
102	514	J12	25	1,27	1,20	*112MB-2	1250	1,12	125	140	1SPZ	416	T
108	486	J12	15	1,50	1,29	*112MB-2	1180	1,75	80	140	2SPZ	415	T
108	487	J12	25	1,32	1,28	*112MB-2	1250	1,06	132	140	1SPZ	411	T
114	459	J12	25	1,37	1,36	*112MB-2	1320	1,00	140	140	1SPZ	439	T
11	6256	J100	20	1,60	1,16	160L-8	2650	3,13	160	500	3SPZ	787	T
12	5943	J100	20	1,68	1,17	160L-8	2650	2,97	160	475	3SPZ	810	T
15	4813	J72	25	1,04	1,37	160M-6	2120	2,67	150	400	3SPZ	614	N
16	4512	J72	25	1,11	1,39	160M -6	2120	2,50	150	375	3SPZ	637	N
18	4030	J72	25	1,24	1,38	160M-6	2000	2,23	150	335	3SPZ	611	N
18	4024	J72	25	1,24	1,27	132M-4	2240	3,33	150	500	2SPZ	582	N
19	3790	J72	25	1,32	1,39	160M-6	2000	2,10	150	315	3SPZ	629	N
19	3823	J72	25	1,31	1,29	132M-4	2240	3,17	150	475	2SPZ	606	N
19	3823	J72	25	1,31	1,31	132M-4	2360	3,17	150	475	2SPZ	669	T
20	3609	J72	25	1,39	1,40	160M-6	2000	2,00	150	300	3SPZ	641	N
21	3369	J72	25	1,48	1,39	160M-6	1900	1,87	150	280	3SPZ	608	N
21	3421	J72	25	1,46	1,29	132M-4	2120	2,83	150	425	2SPZ	592	N
21	3421	J72	25	1,46	1,32	132M-4	2240	2,83	150	425	2SPZ	653	T
22	3236	J72	15	1,55	1,37	160M -6	2240	3,00	150	450	3SPZ	630	N
22	3219	J72	25	1,55	1,31	132M-4	2120	2,67	150	400	2SPZ	614	N
22	3236	J72	25	1,55	1,39	160M -6	2360	3,00	150	450	3SPZ	692	T
22	3219	J72	25	1,55	1,33	132M-4	2240	2,67	150	400	2SPZ	676	T
23	3158	J72	25	1,58	1,03	160M-6	2120	1,75	160	280	2SPZ	711	T
23	3056	J72	15	1,64	1,40	160M -6	2360	2,83	150	425	3SPZ	714	T
25	2857	J72	25	1,75	1,31	132M-4	2000	2,37	150	355	2SPZ	594	N
25	2890	J52	25	1,00	1,29	132M-4	1900	2,37	150	355	2SPZ	543	N
25	2841	J52	15	1,02	1,39	160M-6	2120	2,50	150	375	3SPZ	637	T
25	2857	J52	15	1,75	1,33	132M-4	2120	2,37	150	355	2SPZ	655	T
25	2890	J52	25	1,00	1,31	132M-4	2000	2,37	150	355	2SPZ	594	T
26	2727	J52	25	1,06	1,32	132M-4	2000	2,23	150	335	2SPZ	611	T
28	2564	J52	25	1,13	1,29	132M-4	1800	2,10	150	315	2SPZ	528	N
28	2534	J52	15	1,14	1,24	132M-4	2120	3,33	150	500	2SPZ	519	N
28	2538	J52	15	1,14	1,38	160M-6	2000	2,23	150	335	3SPZ	611	T
28	2534	J52	15	1,14	1,27	132M-4	2240	3,33	150	500	2SPZ	582	T
29	2442	J52	25	1,19	1,30	132M-4	1800	2,00	150	300	2SPZ	541	N
29	2442	J52	25	1,19	1,32	132M-4	1900	2,00	150	300	2SPZ	591	T
30	2407	J52	15	1,20	1,26	132M-4	2120	3,17	150	475	2SPZ	544	N
30	2386	J52	15	1,22	1,39	160M-6	2000	2,10	150	315	3SPZ	629	T
30	2407	J52	15	1,20	1,29	132M-4	2240	3,17	150	475	2SPZ	606	T
31	2279	J52	25	1,27	1,33	132M-4	1900	1,87	150	280	2SPZ	608	T
32	2273	J52	15	1,28	1,40	160M-6	2000	2,00	150	300	3SPZ	641	T
33	2154	J52	15	1,35	1,27	132M-4	2000	2,83	150	425	2SPZ	530	N
33	2157	J52	25	1,34	1,30	132M-4	1700	1,77	150	265	2SPZ	520	N
33	2154	J52	15	1,35	1,29	132M-4	2120	2,83	150	425	2SPZ	592	T
35	2035	J52	25	1,43	1,31	132M-4	1700	1,67	150	250	2SPZ	533	N
35	2035	J52	25	1,43	1,32	132M-4	1800	1,67	150	250	2SPZ	583	T
35	2027	J52	15	1,43	1,31	132M-4	2120	2,67	150	400	2SPZ	614	T

*High efficiency motor

SERIES J

POWER RATINGS V-BELT TRANSMISSIONS

7.50 kW

n2 rpm	T2 Nm	Gear unit	i	fbp SF	V-belt length SF	Motor	V-belt length mm	Pulley Ratio	Pulley D1	Pulley D2	Pulley type	C-C mm	Motor- mount type
36	2008	J52	15	1,44	1,40	160M-6	1900	1,77	150	265	3SPZ	621	T
37	1921	J52	25	1,51	1,31	132M-4	1700	1,57	150	236	2SPZ	544	N
37	1921	J52	25	1,51	1,33	132M-4	1800	1,57	150	236	2SPZ	595	T
38	1901	J52	15	1,53	1,28	132M-4	1900	2,50	150	375	2SPZ	525	N
38	1909	J32	15	1,02	1,25	132M-4	1800	2,50	150	375	2SPZ	473	N
38	1902	J32	15	1,03	1,37	160M-6	1700	1,67	150	250	3SPZ	533	T
38	1909	J32	15	1,02	1,28	132M-4	1900	2,50	150	375	2SPZ	525	T
38	1894	J52	15	1,53	1,40	160M-6	1900	1,67	150	250	3SPZ	633	T
39	1823	J52	25	1,59	1,33	132M-4	1800	1,49	150	224	2SPZ	604	T
40	1799	J52	15	1,61	1,29	132M-4	1900	2,37	150	355	2SPZ	543	N
40	1807	J32	15	1,06	1,27	132M-4	1800	2,37	150	355	2SPZ	492	N
40	1795	J32	15	1,07	1,37	160M-6	1700	1,57	150	236	3SPZ	544	T
40	1799	J52	15	1,61	1,31	132M-4	2000	2,37	150	355	2SPZ	594	T
42	1726	J52	25	1,67	1,30	132M-4	1600	1,41	150	212	2SPZ	514	N
42	1704	J32	15	1,11	1,38	160M-6	1700	1,49	150	224	3SPZ	554	T
42	1726	J52	25	1,67	1,34	132M-4	1800	1,41	150	212	2SPZ	614	T
42	1698	J52	15	1,71	1,32	132M-4	2000	2,23	150	335	2SPZ	611	T
42	1705	J32	15	1,11	1,28	132M-4	1800	2,23	150	335	2SPZ	510	T
42	1687	J32	25	1,02	1,30	132M-4	1600	1,41	150	212	2SPZ	514	T
44	1628	J52	25	1,76	1,31	132M-4	1600	1,33	150	200	2SPZ	524	N
44	1613	J32	15	1,15	1,38	160M-6	1700	1,41	150	212	3SPZ	564	T
45	1592	J32	25	1,06	1,29	132M-4	1500	1,33	150	200	2SPZ	474	N
45	1603	J32	15	1,16	1,27	132M-4	1700	2,10	150	315	2SPZ	477	N
45	1592	J32	25	1,06	1,31	132M-4	1600	1,33	150	200	2SPZ	524	T
45	1603	J32	15	1,16	1,29	132M-4	1800	2,10	150	315	2SPZ	528	T
47	1512	J32	25	1,10	1,29	132M-4	1500	1,27	150	190	2SPZ	482	N
47	1527	J32	15	1,20	1,28	132M-4	1700	2,00	150	300	2SPZ	490	N
47	1512	J32	25	1,10	1,31	132M-4	1600	1,27	150	190	2SPZ	532	T
50	1433	J32	25	1,14	1,29	132M-4	1500	1,20	150	180	2SPZ	490	N
50	1445	J32	15	1,24	1,37	160M-6	1600	1,27	150	190	3SPZ	532	T
50	1425	J32	15	1,26	1,29	132M-4	1700	1,87	150	280	2SPZ	507	T
51	1403	J22	15	1,06	1,27	132M-4	1600	1,87	150	280	2SPZ	457	T
52	1369	J32	15	1,29	1,37	160M-6	1600	1,20	150	180	3SPZ	540	T
53	1343	J32	25	1,20	1,39	132M-4	1500	1,13	160	180	2SPZ	482	N
53	1349	J32	15	1,31	1,28	132M-4	1600	1,77	150	265	2SPZ	470	N
53	1349	J32	15	1,31	1,30	132M-4	1700	1,77	150	265	2SPZ	520	T
54	1328	J22	15	1,11	1,28	132M-4	1600	1,77	150	265	2SPZ	470	T
56	1272	J32	15	1,36	1,29	132M-4	1600	1,67	150	250	2SPZ	483	N
56	1272	J32	15	1,36	1,31	132M-4	1700	1,67	150	250	2SPZ	533	T
57	1253	J22	15	1,15	1,29	132M-4	1600	1,67	150	250	2SPZ	483	T
60	1201	J32	15	1,42	1,29	132M-4	1600	1,57	150	236	2SPZ	494	N
63	1140	J32	15	1,47	1,30	132M-4	1600	1,49	150	224	2SPZ	504	T
64	1123	J22	15	1,25	1,28	132M-4	1500	1,49	150	224	2SPZ	454	T
66	1079	J32	15	1,53	1,30	132M-4	1600	1,41	150	212	2SPZ	514	T
67	1062	J22	15	1,30	1,28	132M-4	1500	1,41	150	212	2SPZ	464	T
70	1018	J32	15	1,59	1,29	132M-4	1500	1,33	150	200	2SPZ	474	N
70	1018	J32	15	1,59	1,31	132M-4	1600	1,33	150	200	2SPZ	524	T
71	1002	J22	15	1,35	1,29	132M-4	1500	1,33	150	200	2SPZ	474	T
74	967	J32	15	1,65	1,29	132M-4	1500	1,27	150	190	2SPZ	482	N
74	967	J32	15	1,65	1,31	132M-4	1600	1,27	150	190	2SPZ	532	T
75	952	J22	15	1,40	1,29	132M-4	1500	1,27	150	190	2SPZ	482	T
78	916	J32	15	1,71	1,29	132M-4	1500	1,20	150	180	2SPZ	490	N
83	859	J32	15	1,79	1,39	132M-4	1500	1,13	160	180	2SPZ	482	N
87	823	J31	5	1,19	1,20	132M-4	2000	3,33	150	500	2SPZ	455	N
87	823	J31	5	1,19	1,24	132M-4	2120	3,33	150	500	2SPZ	519	T
89	802	J22	15	1,58	1,27	132M-4	1400	1,07	150	160	2SPZ	456	T
92	780	J32	25	1,75	1,05	132SB-2	1500	1,29	140	180	1SPZ	498	N
92	782	J31	5	1,23	1,23	132M-4	2000	3,17	150	475	2SPZ	481	N
97	741	J31	5	1,28	1,22	132M-4	1900	3,00	150	450	2SPZ	453	N
97	741	J31	5	1,28	1,25	132M-4	2000	3,00	150	450	2SPZ	506	T
102	700	J31	5	1,33	1,24	132M-4	1900	2,83	150	425	2SPZ	478	N
102	699	J22	25	1,32	1,04	132SB-2	1400	1,14	140	160	1SPZ	464	T

*High
efficiency
motor

SERIES J

POWER RATINGS V-BELT TRANSMISSIONS

7.50 kW

n2 rpm	T2 Nm	Gear unit	i	fbp SF	V-belt length SF	Motor	V-belt length mm	Pulley Ratio	Pulley D1	Pulley D2	Pulley type	C-C mm	Motor- mount type
109	659	J31	5	1,38	1,23	132M-4	1800	2,67	150	400	2SPZ	450	N
109	659	J31	5	1,38	1,26	132M-4	1900	2,67	150	400	2SPZ	502	T
110	652	J22	25	1,38	1,12	132SB-2	1400	1,07	150	160	1SPZ	456	T
116	617	J31	5	1,44	1,25	132M-4	1800	2,50	150	375	2SPZ	473	N
123	585	J31	5	1,49	1,27	132M-4	1800	2,37	150	355	2SPZ	492	T
130	552	J31	5	1,55	1,26	132M-4	1700	2,23	150	335	2SPZ	459	N
130	552	J31	5	1,55	1,28	132M-4	1800	2,23	150	335	2SPZ	510	T
138	519	J31	5	1,62	1,27	132M-4	1700	2,10	150	315	2SPZ	477	N
145	494	J31	5	1,67	1,28	132M-4	1700	2,00	150	300	2SPZ	490	T
155	461	J31	5	1,75	1,27	132M-4	1600	1,87	150	280	2SPZ	457	N
155	461	J31	5	1,75	1,29	132M-4	1700	1,87	150	280	2SPZ	507	T
12	6921	J100	25	1,45	1,27	160L-6	2650	3,13	160	500	3SPZ	787	T
13	6575	J100	25	1,52	1,29	160L-6	2650	2,97	160	475	3SPZ	810	T
15	5883	J100	25	1,70	1,28	160L-6	2500	2,66	160	425	3SPZ	778	T
18	4829	J72	25	1,04	1,06	132MA-4	2240	3,33	150	500	2SPZ	582	N
18	4805	J72	25	1,04	1,27	160L-6	2240	2,22	160	355	3SPZ	708	T
19	4588	J72	25	1,09	1,07	132MA-4	2240	3,17	150	475	2SPZ	606	N
19	4588	J72	25	1,09	1,09	132MA-4	2360	3,17	150	475	2SPZ	669	T
20	4264	J72	25	1,17	1,26	160L-6	2000	1,97	160	315	3SPZ	621	N
20	4264	J72	25	1,17	1,27	160L-6	2120	1,97	160	315	3SPZ	682	T
21	4061	J72	25	1,23	1,26	160L-6	2000	1,88	160	300	3SPZ	634	N
21	4045	J72	15	1,24	1,22	160L-6	2360	3,13	160	500	3SPZ	638	N
21	4105	J72	25	1,22	1,08	132MA-4	2120	2,83	150	425	2SPZ	592	N
21	4061	J72	25	1,23	1,28	160L-6	2120	1,88	160	300	3SPZ	694	T
21	4045	J72	15	1,24	1,25	160L-6	2500	3,13	160	500	3SPZ	710	T
21	4105	J72	25	1,22	1,10	132MA-4	2240	2,83	150	425	2SPZ	653	T
22	3863	J72	25	1,29	1,09	132MA-4	2120	2,67	150	400	2SPZ	614	N
22	3863	J72	25	1,29	1,11	132MA-4	2240	2,67	150	400	2SPZ	676	T
23	3790	J72	25	1,32	1,29	160L-6	2120	1,75	160	280	3SPZ	711	T
24	3640	J72	15	1,37	1,23	160L-6	2240	2,81	160	450	3SPZ	623	N
24	3640	J72	15	1,37	1,25	160L-6	2360	2,81	160	450	3SPZ	685	T
25	3429	J72	25	1,46	1,09	132MA-4	2000	2,37	150	355	2SPZ	594	N
25	3438	J72	15	1,45	1,26	160L-6	2360	2,66	160	425	3SPZ	707	T
25	3429	J72	25	1,46	1,11	132MA-4	2120	2,37	150	355	2SPZ	655	T
27	3129	J72	25	1,60	1,40	132SD-2	2240	4,24	118	500	2SPZ	604	N
27	3236	J72	25	1,55	1,10	132MA-4	2000	2,23	150	335	2SPZ	611	N
27	3236	J72	25	1,55	1,12	132MA-4	2120	2,23	150	335	2SPZ	672	T
28	3033	J72	15	1,65	1,27	160L-6	2240	2,34	160	375	3SPZ	691	T
30	2848	J52	25	1,02	1,37	132SD-2	2000	3,81	118	450	2SPZ	527	N
30	2886	J72	15	1,73	1,06	132MA-4	2240	3,33	150	500	2SPZ	582	N
30	2889	J52	15	1,00	1,05	132MA-4	2120	3,17	150	475	2SPZ	544	N
30	2897	J72	25	1,73	1,10	132MA-4	1900	2,00	150	300	2SPZ	591	N
30	2872	J72	15	1,74	1,27	160L-6	2240	2,22	160	355	3SPZ	708	T
30	2889	J52	15	1,00	1,07	132MA-4	2240	3,17	150	475	2SPZ	606	T
31	2735	J52	25	1,06	1,11	132MA-4	1900	1,87	150	280	2SPZ	608	T
32	2685	J52	15	1,08	1,26	160L-6	2000	1,97	160	315	3SPZ	621	T
33	2588	J52	25	1,12	1,08	132MA-4	1700	1,77	150	265	2SPZ	520	N
33	2585	J52	15	1,12	1,06	132MA-4	2000	2,83	150	425	2SPZ	530	N
33	2585	J52	15	1,12	1,08	132MA-4	2120	2,83	150	425	2SPZ	592	T
34	2531	J52	25	1,15	1,39	132SD-2	1900	3,39	118	400	2SPZ	523	N
34	2557	J52	15	1,13	1,26	160L-6	2000	1,88	160	300	3SPZ	634	T
35	2442	J52	25	1,19	1,09	132MA-4	1700	1,67	150	250	2SPZ	533	N
35	2433	J52	15	1,19	1,09	132MA-4	2120	2,67	150	400	2SPZ	614	T
35	2442	J52	25	1,19	1,10	132MA-4	1800	1,67	150	250	2SPZ	583	T
37	2305	J52	25	1,26	1,09	132MA-4	1700	1,57	150	236	2SPZ	544	N
37	2305	J52	25	1,26	1,11	132MA-4	1800	1,57	150	236	2SPZ	595	T
38	2246	J52	25	1,29	1,39	132SD-2	1800	3,01	118	355	2SPZ	514	N
38	2281	J52	15	1,27	1,07	132MA-4	1900	2,50	150	375	2SPZ	525	N
38	2259	J52	15	1,28	1,26	160L-6	1900	1,66	160	265	3SPZ	613	T
39	2188	J52	25	1,33	1,11	132MA-4	1800	1,49	150	224	2SPZ	604	T
40	2159	J52	15	1,34	1,08	132MA-4	1900	2,37	150	355	2SPZ	543	N

*High efficiency motor

SERIES J

POWER RATINGS V-BELT TRANSMISSIONS

9.00 kW

n2 rpm	T2 Nm	Gear unit	i	fbp SF	V-belt length SF	Motor	V-belt length mm	Pulley Ratio	Pulley D1	Pulley D2	Pulley type	C-C mm	Motor- mount type
40	2131	J52	15	1,36	1,26	160L-6	1900	1,56	160	250	3SPZ	626	T
40	2159	J52	15	1,34	1,09	132MA-4	2000	2,37	150	355	2SPZ	594	T
42	2071	J52	25	1,39	1,09	132MA-4	1600	1,41	150	212	2SPZ	514	N
42	2071	J52	25	1,39	1,11	132MA-4	1800	1,41	150	212	2SPZ	614	T
42	2037	J52	15	1,42	1,10	132MA-4	2000	2,23	150	335	2SPZ	611	T
43	2011	J52	15	1,44	1,27	160L-6	1900	1,48	160	236	3SPZ	637	T
44	1970	J52	15	1,47	1,36	132SD-2	2120	4,24	118	500	2SPZ	540	N
44	1953	J52	25	1,47	1,09	132MA-4	1600	1,33	150	200	2SPZ	524	N
44	1970	J52	15	1,47	1,40	132SD-2	2240	4,24	118	500	2SPZ	604	T
45	1916	J52	15	1,51	1,08	132MA-4	1800	2,10	150	315	2SPZ	528	N
47	1831	J52	25	1,54	1,17	132MA-4	1600	1,25	160	200	2SPZ	516	N
47	1825	J52	15	1,59	1,08	132MA-4	1800	2,00	150	300	2SPZ	541	N
47	1832	J32	15	1,00	1,07	132MA-4	1700	2,00	150	300	2SPZ	490	N
47	1814	J32	15	1,00	1,24	160L-6	1700	1,33	160	212	3SPZ	557	T
47	1831	J52	25	1,54	1,20	132MA-4	1800	1,25	160	200	2SPZ	616	T
47	1825	J52	15	1,59	1,10	132MA-4	1900	2,00	150	300	2SPZ	591	T
48	1773	J52	15	1,64	1,37	132SD-2	2000	3,81	118	450	2SPZ	527	N
48	1781	J32	15	1,02	1,34	132SD-2	1900	3,81	118	450	2SPZ	474	N
48	1781	J32	15	1,02	1,37	132SD-2	2000	3,81	118	450	2SPZ	527	T
50	1705	J52	15	1,70	1,26	160L-6	1800	1,25	160	200	3SPZ	616	T
50	1724	J52	25	1,60	1,29	132MA-4	1800	1,18	170	200	2SPZ	608	T
50	1703	J52	15	1,70	1,11	132MA-4	1900	1,87	150	280	2SPZ	608	T
50	1710	J32	15	1,05	1,08	132MA-4	1700	1,87	150	280	2SPZ	507	T
51	1682	J32	15	1,06	1,36	132SD-2	1900	3,60	118	425	2SPZ	499	N
53	1612	J32	25	1,00	1,16	132MA-4	1500	1,13	160	180	2SPZ	482	N
53	1612	J52	15	1,80	1,08	132MA-4	1700	1,77	150	265	2SPZ	520	N
53	1618	J32	15	1,09	1,07	132MA-4	1600	1,77	150	265	2SPZ	470	N
53	1628	J52	25	1,67	1,37	132MA-4	1800	1,11	180	200	2SPZ	601	T
53	1612	J32	25	1,00	1,17	132MA-4	1600	1,13	160	180	2SPZ	532	T
53	1618	J32	15	1,09	1,08	132MA-4	1700	1,77	150	265	2SPZ	520	T
54	1583	J32	15	1,11	1,36	132SD-2	1800	3,39	118	400	2SPZ	471	N
54	1583	J32	15	1,11	1,39	132SD-2	1900	3,39	118	400	2SPZ	523	T
56	1527	J32	15	1,13	1,07	132MA-4	1600	1,67	150	250	2SPZ	483	N
56	1541	J32	15	1,13	1,23	160L-6	1600	1,13	160	180	3SPZ	532	T
56	1527	J32	15	1,13	1,09	132MA-4	1700	1,67	150	250	2SPZ	533	T
57	1517	J32	25	1,04	1,24	132MA-4	1500	1,06	170	180	2SPZ	474	N
57	1517	J32	25	1,04	1,25	132MA-4	1600	1,06	170	180	2SPZ	524	T
58	1484	J32	15	1,16	1,38	132SD-2	1800	3,18	118	375	2SPZ	495	N
59	1460	J32	25	1,07	1,40	132SD-2	1500	2,00	118	236	2SPZ	468	N
60	1441	J32	15	1,18	1,08	132MA-4	1600	1,57	150	236	2SPZ	494	N
60	1433	J32	25	1,08	1,30	132MA-4	1500	1,00	180	180	2SPZ	467	N
60	1433	J32	25	1,08	1,32	132MA-4	1600	1,00	180	180	2SPZ	517	T
61	1405	J32	15	1,20	1,39	132SD-2	1800	3,01	118	355	2SPZ	514	T
62	1383	J22	15	1,02	1,37	132SD-2	1700	3,01	118	355	2SPZ	463	T
63	1368	J32	15	1,22	1,08	132MA-4	1600	1,49	150	224	2SPZ	504	T
64	1347	J22	15	1,04	1,07	132MA-4	1500	1,49	150	224	2SPZ	454	T
65	1326	J32	15	1,25	1,38	132SD-2	1700	2,84	118	335	2SPZ	481	N
66	1305	J22	15	1,06	1,38	132SD-2	1700	2,84	118	335	2SPZ	481	T
66	1295	J32	15	1,27	1,09	132MA-4	1600	1,41	150	212	2SPZ	514	T
67	1275	J22	15	1,08	1,07	132MA-4	1500	1,41	150	212	2SPZ	464	T
69	1246	J32	15	1,31	1,40	132SD-2	1700	2,67	118	315	2SPZ	499	N
70	1221	J32	15	1,33	1,07	132MA-4	1500	1,33	150	200	2SPZ	474	N
70	1221	J32	15	1,33	1,09	132MA-4	1600	1,33	150	200	2SPZ	524	T
71	1203	J22	15	1,12	1,07	132MA-4	1500	1,33	150	200	2SPZ	474	T
74	1160	J32	15	1,37	1,07	132MA-4	1500	1,27	150	190	2SPZ	482	N
74	1169	J22	15	1,15	1,38	132SD-2	1600	2,54	118	300	2SPZ	462	T
74	1160	J32	15	1,37	1,09	132MA-4	1600	1,27	150	190	2SPZ	532	T
75	1143	J22	15	1,17	1,07	132MA-4	1500	1,27	150	190	2SPZ	482	T
78	1099	J32	15	1,43	1,07	132MA-4	1500	1,20	150	180	2SPZ	490	N
78	1108	J32	15	1,42	1,40	132SD-2	1600	2,37	118	280	2SPZ	480	N
79	1091	J22	15	1,20	1,40	132SD-2	1600	2,37	118	280	2SPZ	480	T
83	1031	J32	15	1,49	1,16	132MA-4	1500	1,13	160	180	2SPZ	482	N
83	1031	J32	15	1,49	1,17	132MA-4	1600	1,13	160	180	2SPZ	532	T

*High
efficiency
motor

SERIES J

POWER RATINGS V-BELT TRANSMISSIONS

9.00 kW

n2 rpm	T2 Nm	Gear unit	i	fbp SF	V-belt length SF	Motor	V-belt length mm	Pulley Ratio	Pulley D1	Pulley D2	Pulley type	C-C mm	Motor- mount type
88	974	J22	15	1,30	1,39	132SD-2	1500	2,12	118	250	2SPZ	455	T
89	970	J32	15	1,56	1,24	132MA-4	1500	1,06	170	180	2SPZ	474	N
89	970	J32	15	1,56	1,25	132MA-4	1600	1,06	170	180	2SPZ	524	T
89	962	J22	15	1,31	1,06	132MA-4	1400	1,07	150	160	2SPZ	456	T
92	939	J31	5	1,02	1,02	132MA-4	2000	3,17	150	475	2SPZ	481	N
92	934	J32	15	1,60	1,40	132SD-2	1500	2,00	118	236	2SPZ	468	N
93	919	J22	15	1,36	1,40	132SD-2	1500	2,00	118	236	2SPZ	468	T
94	916	J32	15	1,62	1,30	132MA-4	1500	1,00	180	180	2SPZ	467	N
94	916	J32	15	1,62	1,32	132MA-4	1600	1,00	180	180	2SPZ	517	T
97	889	J31	5	1,06	1,01	132MA-4	1900	3,00	150	450	2SPZ	453	N
97	889	J31	5	1,06	1,04	132MA-4	2000	3,00	150	450	2SPZ	506	T
102	840	J31	5	1,10	1,03	132MA-4	1900	2,83	150	425	2SPZ	478	N
105	821	J32	25	1,60	1,01	132SD-2	1500	1,13	160	180	1SPZ	482	N
105	821	J32	25	1,60	1,03	132SD-2	1600	1,13	160	180	1SPZ	532	T
109	790	J31	5	1,15	1,03	132MA-4	1800	2,67	150	400	2SPZ	450	N
109	790	J31	5	1,15	1,05	132MA-4	1900	2,67	150	400	2SPZ	502	T
111	773	J32	25	1,67	1,08	132SD-2	1500	1,06	170	180	1SPZ	474	N
111	773	J32	25	1,67	1,09	132SD-2	1600	1,06	170	180	1SPZ	524	T
116	741	J31	5	1,20	1,05	132MA-4	1800	2,50	150	375	2SPZ	473	N
116	740	J22	15	1,58	1,40	132SD-2	1400	1,61	118	190	2SPZ	456	T
118	730	J32	25	1,73	1,13	132SD-2	1500	1,00	180	180	1SPZ	467	N
118	730	J32	25	1,73	1,14	132SD-2	1600	1,00	180	180	1SPZ	517	T
123	701	J31	5	1,25	1,06	132MA-4	1800	2,37	150	355	2SPZ	492	T
123	701	J22	15	1,64	1,40	132SD-2	1400	1,53	118	180	2SPZ	464	T
130	662	J31	5	1,29	1,05	132MA-4	1700	2,23	150	335	2SPZ	459	N
130	662	J31	5	1,29	1,07	132MA-4	1800	2,23	150	335	2SPZ	510	T
138	622	J31	5	1,35	1,06	132MA-4	1700	2,10	150	315	2SPZ	477	N
145	593	J31	5	1,39	1,07	132MA-4	1700	2,00	150	300	2SPZ	490	T
155	553	J31	5	1,46	1,06	132MA-4	1600	1,87	150	280	2SPZ	457	N
155	553	J31	5	1,46	1,08	132MA-4	1700	1,87	150	280	2SPZ	507	T
164	524	J31	5	1,51	1,07	132MA-4	1600	1,77	150	265	2SPZ	470	N
164	524	J31	5	1,51	1,08	132MA-4	1700	1,77	150	265	2SPZ	520	T
174	494	J31	5	1,57	1,07	132MA-4	1600	1,67	150	250	2SPZ	483	N
184	466	J31	5	1,63	1,08	132MA-4	1600	1,57	150	236	2SPZ	494	T
194	443	J31	5	1,69	1,07	132MA-4	1500	1,49	150	224	2SPZ	454	N
194	443	J31	5	1,69	1,08	132MA-4	1600	1,49	150	224	2SPZ	504	T
205	419	J31	5	1,75	1,07	132MA-4	1500	1,41	150	212	2SPZ	464	N
205	419	J31	5	1,75	1,09	132MA-4	1600	1,41	150	212	2SPZ	514	T

11.0 kW

11	9170	J110	20	1,54	1,09	180L-8	3150	3,15	200	630	2SPA	896	T
11	9185	J100	20	1,09	1,07	180L-8	3000	3,15	200	630	2SPA	819	T
13	8151	J110	20	1,74	1,10	180L-8	3000	2,80	200	560	2SPA	884	T
14	7727	J100	20	1,29	1,08	180L-8	2800	2,65	200	530	2SPA	809	T
14	7580	J100	25	1,32	1,40	160L-6	2800	2,80	200	560	2SPA	781	T
17	6060	J100	20	1,65	1,40	160L-6	2800	2,80	200	560	2SPA	781	T
18	5995	J100	25	1,67	1,39	160M-4	2650	3,33	150	500	3SPZ	794	T
21	4983	J72	15	1,00	1,33	160L-6	2650	3,15	200	630	2SPA	636	N
21	5017	J72	25	1,00	1,32	*132MB-4	2120	2,83	150	425	3SPZ	592	N
21	4983	J72	25	1,00	1,38	160M-4	2360	2,83	150	425	3SPZ	714	T
21	4983	J72	15	1,00	1,36	160L-6	2800	3,15	200	630	2SPA	715	T
21	5017	J72	25	1,00	1,35	*132MB-4	2240	2,83	150	425	3SPZ	653	T
22	4689	J72	25	1,07	1,35	160M-4	2120	2,67	150	400	3SPZ	614	N
22	4698	J72	25	1,06	1,39	160L-6	2120	1,77	200	355	2SPA	618	N
22	4722	J72	25	1,06	1,34	*132MB-4	2120	2,67	150	400	3SPZ	614	N
22	4722	J72	25	1,06	1,36	*132MB-4	2240	2,67	150	400	3SPZ	676	T
24	4396	J72	25	1,14	1,36	160M-4	2120	2,50	150	375	3SPZ	637	N
24	4429	J72	15	1,13	1,34	160L-6	2500	2,80	200	560	2SPA	626	N
24	4434	J72	25	1,13	1,40	160L-6	2120	1,67	200	335	2SPA	635	N
24	4396	J72	25	1,14	1,38	160M-4	2240	2,50	150	375	3SPZ	698	T
24	4429	J72	15	1,13	1,38	160L-6	2650	2,80	200	560	2SPA	704	T
25	4191	J72	25	1,19	1,34	*132MB-4	2000	2,37	150	355	3SPZ	594	N
25	4162	J72	25	1,20	1,39	160M-4	2240	2,37	150	355	3SPZ	715	T

*High efficiency motor

SERIES J

POWER RATINGS V-BELT TRANSMISSIONS

11.0 kW

n2 rpm	T2 Nm	Gear unit	i	fbp SF	V-belt length SF	Motor	V-belt length mm	Pulley Ratio	Pulley D1	Pulley D2	Pulley type	C-C mm	Motor- mount type
25	4191	J72	25	1,19	1,36	*132MB-4	2120	2,37	150	355	3SPZ	655	T
27	3927	J72	25	1,27	1,36	160M-4	2000	2,23	150	335	3SPZ	611	N
27	3837	J72	25	1,30	1,14	*132SC-2	2240	4,24	118	500	2SPZ	604	N
27	3955	J72	25	1,26	1,35	*132MB-4	2000	2,23	150	335	3SPZ	611	N
27	3955	J72	15	1,26	1,38	160L-6	2500	2,50	200	500	2SPA	683	T
27	3837	J72	25	1,30	1,17	*132SC-2	2360	4,24	118	500	2SPZ	666	T
27	3955	J72	25	1,26	1,37	*132MB-4	2120	2,23	150	335	3SPZ	672	T
28	3693	J72	25	1,35	1,37	160M-4	2000	2,10	150	315	3SPZ	629	N
28	3693	J72	25	1,35	1,39	160M-4	2120	2,10	150	315	3SPZ	689	T
28	3757	J72	15	1,33	1,40	160L-6	2500	2,38	200	475	2SPA	706	T
30	3527	J72	25	1,42	1,19	160MA-2	2240	4,03	118	475	2SPZ	628	N
30	3517	J72	25	1,42	1,38	160M-4	2000	2,00	150	300	3SPZ	641	N
30	3454	J72	25	1,45	1,15	*132SC-2	2120	3,81	118	450	2SPZ	590	N
30	3541	J72	25	1,41	1,35	*132MB-4	1900	2,00	150	300	3SPZ	591	N
30	3527	J72	15	1,42	1,30	*132MB-4	2240	3,33	150	500	3SPZ	582	N
30	3527	J72	25	1,42	1,21	160MA-2	2360	4,03	118	475	2SPZ	690	T
30	3517	J72	25	1,42	1,39	160M-4	2120	2,00	150	300	3SPZ	702	T
30	3454	J72	25	1,45	1,17	*132SC-2	2240	3,81	118	450	2SPZ	652	T
31	3351	J72	15	1,49	1,32	*132MB-4	2240	3,17	150	475	3SPZ	606	N
31	3342	J72	25	1,50	1,22	160MA-2	2360	3,81	118	450	2SPZ	714	T
31	3351	J72	15	1,49	1,34	*132MB-4	2360	3,17	150	475	3SPZ	669	T
32	3283	J72	25	1,52	1,37	160M-4	1900	1,87	150	280	3SPZ	608	N
32	3262	J72	25	1,53	1,16	*132SC-2	2120	3,60	118	425	2SPZ	614	N
32	3305	J72	25	1,51	1,36	*132MB-4	1900	1,87	150	280	3SPZ	608	N
32	3262	J72	25	1,53	1,18	*132SC-2	2240	3,60	118	425	2SPZ	675	T
32	3305	J72	25	1,51	1,38	*132MB-4	2000	1,87	150	280	3SPZ	658	T
33	3156	J72	25	1,58	1,19	160MA-2	2120	3,60	118	425	2SPZ	614	N
33	3153	J72	15	1,59	1,34	160M-4	2240	3,00	150	450	3SPZ	630	N
33	3153	J72	15	1,59	1,37	160M-4	2360	3,00	150	450	3SPZ	692	T
34	3077	J72	25	1,62	1,01	160M-4	2120	1,75	160	280	2SPZ	711	T
35	2970	J72	25	1,68	1,21	160MA-2	2120	3,39	118	400	2SPZ	637	N
35	2998	J72	15	1,67	1,32	*132MB-4	2120	2,83	150	425	3SPZ	592	N
35	2970	J72	25	1,68	1,23	160MA-2	2240	3,39	118	400	2SPZ	698	T
35	2978	J72	15	1,68	1,38	160M-4	2360	2,83	150	425	3SPZ	714	T
35	2998	J72	15	1,67	1,35	*132MB-4	2240	2,83	150	425	3SPZ	653	T
36	2896	J72	25	1,73	1,07	160M-4	2000	1,65	170	280	2SPZ	643	N
36	2878	J72	25	1,74	1,17	*132SC-2	2000	3,18	118	375	2SPZ	598	N
36	2911	J52	25	1,00	1,15	*132SC-2	1900	3,18	118	375	2SPZ	547	N
36	2916	J72	25	1,71	1,05	*132MB-4	1900	1,65	170	280	2SPZ	593	N
36	2896	J72	25	1,73	1,08	160M-4	2120	1,65	170	280	2SPZ	704	T
36	2878	J72	25	1,74	1,19	*132SC-2	2120	3,18	118	375	2SPZ	659	T
36	2911	J52	25	1,00	1,17	*132SC-2	2000	3,18	118	375	2SPZ	598	T
37	2803	J72	15	1,78	1,35	160M-4	2120	2,67	150	400	3SPZ	614	N
37	2822	J72	15	1,77	1,34	*132MB-4	2120	2,67	150	400	3SPZ	614	N
37	2817	J52	25	1,03	1,34	*132MB-4	1700	1,57	150	236	3SPZ	544	N
37	2822	J72	15	1,77	1,36	*132MB-4	2240	2,67	150	400	3SPZ	676	T
37	2817	J52	25	1,03	1,36	*132MB-4	1800	1,57	150	236	3SPZ	595	T
38	2755	J52	25	1,05	1,14	*132SC-2	1800	3,01	118	355	2SPZ	514	N
38	2787	J52	15	1,04	1,31	*132MB-4	1900	2,50	150	375	3SPZ	525	N
38	2798	J52	25	1,04	1,38	160M-4	1900	1,57	150	236	3SPZ	645	T
38	2768	J52	15	1,05	1,36	160M-4	2120	2,50	150	375	3SPZ	637	T
38	2755	J52	25	1,05	1,18	*132SC-2	2000	3,01	118	355	2SPZ	616	T
38	2792	J52	15	1,04	1,40	160L-6	2120	1,67	200	335	2SPA	635	T
39	2666	J52	25	1,09	1,21	160MA-2	2000	3,01	118	355	2SPZ	616	T
39	2674	J52	25	1,08	1,36	*132MB-4	1800	1,49	150	224	3SPZ	604	T
40	2600	J52	25	1,11	1,15	*132SC-2	1800	2,84	118	335	2SPZ	532	N
40	2639	J52	15	1,10	1,32	*132MB-4	1900	2,37	150	355	3SPZ	543	N
40	2600	J52	25	1,11	1,17	*132SC-2	1900	2,84	118	335	2SPZ	583	T
40	2639	J52	15	1,10	1,34	*132MB-4	2000	2,37	150	355	3SPZ	594	T
42	2531	J52	25	1,14	1,33	*132MB-4	1600	1,41	150	212	3SPZ	514	N
42	2516	J52	25	1,15	1,22	160MA-2	2000	2,84	118	335	2SPZ	634	T
42	2514	J52	25	1,15	1,37	160M-4	1800	1,41	150	212	3SPZ	614	T

*High
efficiency
motor

SERIES J

POWER RATINGS V-BELT TRANSMISSIONS

11.0 kW

n2 rpm	T2 Nm	Gear unit	i	fbp SF	V-belt length SF	Motor	V-belt length mm	Pulley Ratio	Pulley D1	Pulley D2	Pulley type	C-C mm	Motor- mount type
42	2473	J52	15	1,17	1,36	160M-4	2000	2,23	150	335	3SPZ	611	T
42	2531	J52	25	1,14	1,37	*132MB-4	1800	1,41	150	212	3SPZ	614	T
42	2490	J52	15	1,16	1,35	*132MB-4	2000	2,23	150	335	3SPZ	611	T
43	2416	J52	15	1,20	1,11	*132SC-2	2120	4,24	118	500	2SPZ	540	N
43	2445	J52	25	1,18	1,18	*132SC-2	1900	2,67	118	315	2SPZ	601	T
43	2416	J52	15	1,20	1,14	*132SC-2	2240	4,24	118	500	2SPZ	604	T
44	2388	J52	25	1,20	1,33	*132MB-4	1600	1,33	150	200	3SPZ	524	N
44	2371	J52	25	1,21	1,38	160M-4	1800	1,33	150	200	3SPZ	624	T
45	2341	J52	15	1,24	1,32	*132MB-4	1800	2,10	150	315	3SPZ	528	N
45	2325	J52	15	1,25	1,37	160M-4	2000	2,10	150	315	3SPZ	629	T
45	2329	J52	25	1,23	1,19	*132SC-2	1900	2,54	118	300	2SPZ	614	T
45	2333	J52	15	1,24	1,40	160L-6	2000	1,40	200	280	2SPA	621	T
47	2230	J52	15	1,30	1,33	*132MB-4	1800	2,00	150	300	3SPZ	541	N
47	2253	J52	25	1,26	1,22	160MA-2	1900	2,54	118	300	2SPZ	614	T
47	2221	J52	15	1,31	1,19	160MA-2	2240	4,03	118	475	2SPZ	628	T
47	2215	J52	15	1,31	1,38	160M-4	2000	2,00	150	300	3SPZ	641	T
47	2230	J52	15	1,30	1,35	*132MB-4	1900	2,00	150	300	3SPZ	591	T
48	2173	J52	25	1,29	1,16	*132SC-2	1700	2,37	118	280	2SPZ	530	N
48	2175	J52	15	1,33	1,12	*132SC-2	2000	3,81	118	450	2SPZ	527	N
48	2175	J52	15	1,33	1,15	*132SC-2	2120	3,81	118	450	2SPZ	590	T
48	2208	J52	15	1,31	1,40	160L-6	2000	1,33	200	265	2SPA	633	T
50	2103	J52	25	1,31	1,23	160MA-2	1900	2,37	118	280	2SPZ	631	T
50	2081	J52	15	1,39	1,36	*132MB-4	1900	1,87	150	280	3SPZ	608	T
50	2107	J52	25	1,31	1,05	*132MB-4	1800	1,18	170	200	2SPZ	608	T
50	2083	J52	15	1,39	1,40	160L-6	2000	1,25	200	250	2SPA	645	T
51	2057	J52	25	1,33	1,17	*132SC-2	1700	2,25	118	265	2SPZ	543	N
51	2057	J52	25	1,33	1,18	*132SC-2	1800	2,25	118	265	2SPZ	594	T
51	2054	J52	15	1,41	1,16	*132SC-2	2120	3,60	118	425	2SPZ	614	T
53	1970	J52	15	1,47	1,33	*132MB-4	1700	1,77	150	265	3SPZ	520	N
53	1990	J52	25	1,36	1,23	160MA-2	1900	2,25	118	265	2SPZ	644	T
53	1987	J52	15	1,46	1,19	160MA-2	2120	3,60	118	425	2SPZ	614	T
53	1990	J52	25	1,36	1,12	*132MB-4	1800	1,11	180	200	2SPZ	601	T
54	1933	J52	15	1,50	1,13	*132SC-2	1900	3,39	118	400	2SPZ	523	N
54	1956	J52	15	1,48	1,37	160M-4	1900	1,77	150	265	3SPZ	621	T
54	1940	J52	25	1,39	1,19	*132SC-2	1800	2,12	118	250	2SPZ	607	T
56	1885	J52	25	1,41	1,18	*132MB-4	1700	1,05	190	200	2SPZ	543	N
56	1870	J52	15	1,55	1,21	160MA-2	2120	3,39	118	400	2SPZ	637	T
56	1872	J52	25	1,42	1,21	160M-4	1900	1,05	190	200	2SPZ	643	T
56	1867	J52	15	1,55	1,39	160L-6	1900	1,12	200	224	2SPA	616	T
56	1885	J52	25	1,41	1,19	*132MB-4	1800	1,05	190	200	2SPZ	593	T
57	1832	J52	25	1,44	1,16	*132SC-2	1600	2,00	118	236	2SPZ	518	N
57	1858	J52	15	1,56	1,34	*132MB-4	1700	1,67	150	250	3SPZ	533	N
57	1846	J52	15	1,57	1,38	160M-4	1900	1,67	150	250	3SPZ	633	T
57	1858	J52	15	1,56	1,35	*132MB-4	1800	1,67	150	250	3SPZ	583	T
58	1812	J52	15	1,60	1,15	*132SC-2	1900	3,18	118	375	2SPZ	547	N
58	1812	J52	15	1,60	1,17	*132SC-2	2000	3,18	118	375	2SPZ	598	T
59	1791	J52	25	1,46	1,23	*132MB-4	1700	1,00	200	200	2SPZ	535	N
59	1772	J52	25	1,47	1,23	160MA-2	1800	2,00	118	236	2SPZ	618	T
59	1778	J52	25	1,47	1,26	160M-4	1900	1,00	200	200	2SPZ	635	T
59	1767	J52	15	1,64	1,38	160L-6	1900	1,06	200	212	2SPA	626	T
59	1791	J52	25	1,46	1,24	*132MB-4	1800	1,00	200	200	2SPZ	585	T
60	1739	J52	25	1,49	1,17	*132SC-2	1600	1,90	118	224	2SPZ	528	N
60	1754	J52	15	1,65	1,34	*132MB-4	1700	1,57	150	236	3SPZ	544	N
60	1742	J52	15	1,66	1,38	160M-4	1900	1,57	150	236	3SPZ	645	T
60	1754	J52	15	1,65	1,36	*132MB-4	1800	1,57	150	236	3SPZ	595	T
61	1716	J52	15	1,69	1,14	*132SC-2	1800	3,01	118	355	2SPZ	514	N
61	1716	J52	15	1,69	1,18	*132SC-2	2000	3,01	118	355	2SPZ	616	T
62	1682	J52	25	1,53	1,23	160MA-2	1800	1,90	118	224	2SPZ	628	T
63	1660	J52	15	1,75	1,21	160MA-2	2000	3,01	118	355	2SPZ	616	T
63	1667	J32	15	1,00	1,19	160MA-2	1900	3,01	118	355	2SPZ	565	T
63	1661	J32	15	1,01	1,35	160M-4	1700	1,49	150	224	3SPZ	554	T
63	1667	J52	15	1,74	1,36	160L-6	1900	1,00	200	200	2SPA	635	T

*High
efficiency
motor

SERIES J

POWER RATINGS V-BELT TRANSMISSIONS

11.0 kW

n2 rpm	T2 Nm	Gear unit	i	fbp SF	V-belt length SF	Motor	V-belt length mm	Pulley Ratio	Pulley D1	Pulley D2	Pulley type	C-C mm	Motor- mount type
63	1674	J32	15	1,00	1,33	160L-6	1700	1,00	200	200	2SPA	535	T
63	1665	J52	15	1,74	1,36	*132MB-4	1800	1,49	150	224	3SPZ	604	T
63	1672	J32	15	1,00	1,33	*132MB-4	1600	1,49	150	224	3SPZ	504	T
64	1645	J52	25	1,55	1,17	*132SC-2	1600	1,80	118	212	2SPZ	538	N
64	1645	J52	25	1,55	1,19	*132SC-2	1700	1,80	118	212	2SPZ	588	T
65	1619	J52	15	1,79	1,15	*132SC-2	1800	2,84	118	335	2SPZ	532	N
65	1626	J32	15	1,02	1,13	*132SC-2	1700	2,84	118	335	2SPZ	481	N
65	1619	J52	15	1,79	1,17	*132SC-2	1900	2,84	118	335	2SPZ	583	T
65	1626	J32	15	1,02	1,15	*132SC-2	1800	2,84	118	335	2SPZ	532	T
66	1592	J52	25	1,58	1,23	160MA-2	1800	1,80	118	212	2SPZ	638	T
66	1590	J32	15	1,04	1,33	160L-6	1700	0,95	190	200	2SPA	543	T
66	1582	J32	15	1,04	1,33	*132MB-4	1600	1,41	150	212	3SPZ	514	T
67	1573	J32	15	1,05	1,18	160MA-2	1800	2,84	118	335	2SPZ	532	T
67	1572	J32	15	1,05	1,36	160M-4	1700	1,41	150	212	3SPZ	564	T
68	1552	J52	25	1,61	1,17	*132SC-2	1600	1,69	118	200	2SPZ	548	N
68	1552	J52	25	1,61	1,19	*132SC-2	1700	1,69	118	200	2SPZ	598	T
69	1529	J32	15	1,07	1,14	*132SC-2	1700	2,67	118	315	2SPZ	499	N
70	1493	J32	15	1,08	1,32	*132MB-4	1500	1,33	150	200	3SPZ	474	N
70	1506	J32	15	1,08	1,31	160L-6	1700	0,90	180	200	2SPA	551	T
70	1493	J32	15	1,08	1,33	*132MB-4	1600	1,33	150	200	3SPZ	524	T
71	1479	J32	15	1,09	1,19	160MA-2	1800	2,67	118	315	2SPZ	550	T
72	1465	J52	25	1,67	1,26	*132SC-2	1600	1,60	125	200	2SPZ	543	N
72	1469	J32	25	1,00	1,21	160MA-2	1600	1,69	118	200	2SPZ	548	T
72	1465	J52	25	1,67	1,28	*132SC-2	1700	1,60	125	200	2SPZ	593	T
72	1456	J32	15	1,10	1,15	*132SC-2	1700	2,54	118	300	2SPZ	513	T
73	1442	J32	25	1,01	1,16	*132SC-2	1500	1,61	118	190	2SPZ	506	T
74	1418	J32	15	1,12	1,32	*132MB-4	1500	1,27	150	190	3SPZ	482	N
74	1418	J52	25	1,71	1,33	160MA-2	1800	1,60	125	200	2SPZ	643	T
74	1418	J32	15	1,12	1,34	*132MB-4	1600	1,27	150	190	3SPZ	532	T
75	1395	J32	25	1,04	1,21	160MA-2	1600	1,61	118	190	2SPZ	556	T
75	1409	J32	15	1,13	1,34	160M-4	1600	1,27	150	190	3SPZ	532	T
75	1409	J32	15	1,13	1,20	160MA-2	1800	2,54	118	300	2SPZ	564	T
76	1388	J52	25	1,73	1,35	*132SC-2	1600	1,52	132	200	2SPZ	537	N
76	1388	J52	25	1,73	1,37	*132SC-2	1700	1,52	132	200	2SPZ	588	T
77	1359	J32	15	1,16	1,14	*132SC-2	1600	2,37	118	280	2SPZ	480	N
77	1359	J32	15	1,16	1,16	*132SC-2	1700	2,37	118	280	2SPZ	530	T
77	1366	J32	25	1,05	1,16	*132SC-2	1500	1,53	118	180	2SPZ	514	T
78	1344	J32	15	1,17	1,32	*132MB-4	1500	1,20	150	180	3SPZ	490	N
79	1322	J32	25	1,08	1,21	160MA-2	1600	1,53	118	180	2SPZ	564	T
79	1334	J32	15	1,17	1,34	160M-4	1600	1,20	150	180	3SPZ	540	T
80	1315	J32	15	1,19	1,19	160MA-2	1700	2,37	118	280	2SPZ	530	T
81	1290	J32	25	1,10	1,25	*132SC-2	1500	1,44	125	180	2SPZ	509	T
82	1286	J32	15	1,20	1,15	*132SC-2	1600	2,25	118	265	2SPZ	493	N
84	1248	J32	25	1,12	1,30	160MA-2	1600	1,44	125	180	2SPZ	559	T
84	1244	J32	15	1,23	1,20	160MA-2	1700	2,25	118	265	2SPZ	543	T
85	1234	J51	5	1,60	1,34	160L-6	2120	2,25	200	450	2SPA	534	N
85	1234	J51	5	1,60	1,36	160L-6	2240	2,25	200	450	2SPA	595	T
86	1223	J51	5	1,61	1,27	*132MB-4	2120	3,33	150	500	3SPZ	519	N
86	1221	J32	25	1,14	1,33	*132SC-2	1500	1,36	132	180	2SPZ	504	T
86	1223	J51	5	1,61	1,30	*132MB-4	2240	3,33	150	500	3SPZ	582	T
87	1214	J51	5	1,62	1,27	160M-4	2120	3,33	150	500	3SPZ	519	N
87	1213	J32	15	1,25	1,16	*132SC-2	1600	2,12	118	250	2SPZ	506	T
88	1195	J22	15	1,06	1,14	*132SC-2	1500	2,12	118	250	2SPZ	455	T
89	1186	J32	15	1,27	1,01	*132MB-4	1500	1,06	170	180	2SPZ	474	N
89	1182	J32	25	1,17	1,39	160MA-2	1600	1,36	132	180	2SPZ	554	T
89	1176	J22	15	1,08	1,29	*132MB-4	1400	1,07	150	160	3SPZ	456	T
89	1186	J32	15	1,27	1,03	*132MB-4	1600	1,06	170	180	2SPZ	524	T
89	1174	J32	15	1,28	1,20	160MA-2	1700	2,12	118	250	2SPZ	556	T
90	1165	J51	5	1,66	1,38	160L-6	2240	2,13	200	425	2SPA	618	T
91	1153	J51	5	1,67	1,30	160M-4	2120	3,17	150	475	3SPZ	544	N
91	1153	J51	5	1,67	1,33	160M-4	2240	3,17	150	475	3SPZ	606	T
92	1145	J32	15	1,31	1,14	*132SC-2	1500	2,00	118	236	2SPZ	468	N

*High
efficiency
motor

SERIES J

POWER RATINGS V-BELT TRANSMISSIONS

11.0 kW

n2 rpm	T2 Nm	Gear unit	i	fbp SF	V-belt length SF	Motor	V-belt length mm	Pulley Ratio	Pulley D1	Pulley D2	Pulley type	C-C mm	Motor- mount type
92	1145	J32	15	1,31	1,16	*132SC-2	1600	2,00	118	236	2SPZ	518	T
93	1128	J22	15	1,11	1,14	*132SC-2	1500	2,00	118	236	2SPZ	468	T
94	1120	J32	15	1,33	1,07	*132MB-4	1500	1,00	180	180	2SPZ	467	N
94	1120	J32	15	1,33	1,08	*132MB-4	1600	1,00	180	180	2SPZ	517	T
95	1100	J51	5	1,73	1,28	*132MB-4	2000	3,00	150	450	3SPZ	506	N
95	1100	J51	5	1,73	1,31	*132MB-4	2120	3,00	150	450	3SPZ	568	T
96	1097	J51	5	1,73	1,34	160L-6	2000	2,00	200	400	2SPA	518	N
97	1087	J32	15	1,35	1,15	*132SC-2	1500	1,90	118	224	2SPZ	478	N
97	1087	J32	15	1,35	1,17	*132SC-2	1600	1,90	118	224	2SPZ	528	T
98	1070	J22	15	1,15	1,15	*132SC-2	1500	1,90	118	224	2SPZ	478	T
101	1039	J51	5	1,79	1,32	*132MB-4	2120	2,83	150	425	3SPZ	592	T
102	1029	J32	15	1,41	1,15	*132SC-2	1500	1,80	118	212	2SPZ	488	N
102	1032	J51	5	1,80	1,30	160M-4	2000	2,83	150	425	3SPZ	530	N
102	1032	J51	5	1,80	1,33	160M-4	2120	2,83	150	425	3SPZ	592	T
106	995	J32	15	1,44	1,20	160MA-2	1600	1,80	118	212	2SPZ	538	T
108	971	J32	15	1,47	1,16*	132SC-2	1500	1,69	118	200	2SPZ	498	N
112	939	J32	15	1,50	1,21	160MA-2	1600	1,69	118	200	2SPZ	548	T
114	922	J32	15	1,52	1,16	*132SC-2	1500	1,61	118	190	2SPZ	506	T
116	908	J22	15	1,29	1,14	*132SC-2	1400	1,61	118	190	2SPZ	456	T
118	892	J32	15	1,55	1,21	160MA-2	1600	1,61	118	190	2SPZ	556	T
120	874	J32	15	1,58	1,16	*132SC-2	1500	1,53	118	180	2SPZ	514	T
122	860	J22	15	1,34	1,15	*132SC-2	1400	1,53	118	180	2SPZ	464	T
123	857	J31	5	1,02	1,30	*132MB-4	1800	2,37	150	355	3SPZ	492	T
124	845	J32	15	1,61	1,21	160MA-2	1600	1,53	118	180	2SPZ	564	T
127	825	J32	15	1,64	1,25	*132SC-2	1500	1,44	125	180	2SPZ	509	T
129	812	J22	15	1,39	1,15	*132SC-2	1400	1,44	118	170	2SPZ	472	T
130	809	J31	5	1,06	1,29	*132MB-4	1700	2,23	150	335	3SPZ	459	N
130	809	J31	5	1,06	1,31	*132MB-4	1800	2,23	150	335	3SPZ	510	T
132	798	J32	15	1,68	1,30	160MA-2	1600	1,44	125	180	2SPZ	559	T
135	781	J32	15	1,71	1,33	*132SC-2	1500	1,36	132	180	2SPZ	504	T
137	765	J22	15	1,45	1,15	*132SC-2	1400	1,36	118	160	2SPZ	481	T
138	761	J31	5	1,10	1,30	*132MB-4	1700	2,10	150	315	3SPZ	477	N
139	756	J32	15	1,75	1,39	160MA-2	1600	1,36	132	180	2SPZ	554	T
145	724	J31	5	1,14	1,31	*132MB-4	1700	2,00	150	300	3SPZ	490	T
146	722	J22	15	1,51	1,23	*132SC-2	1400	1,28	125	160	2SPZ	475	T
154	683	J22	15	1,57	1,31	*132SC-2	1400	1,21	132	160	2SPZ	470	T
155	676	J31	5	1,19	1,30	*132MB-4	1600	1,87	150	280	3SPZ	457	N
155	676	J31	5	1,19	1,32	*132MB-4	1700	1,87	150	280	3SPZ	507	T
163	644	J22	15	1,64	1,40	*132SC-2	1400	1,14	140	160	2SPZ	464	T
164	640	J31	5	1,24	1,31	*132MB-4	1600	1,77	150	265	3SPZ	470	N
164	640	J31	5	1,24	1,33	*132MB-4	1700	1,77	150	265	3SPZ	520	T
174	604	J31	5	1,29	1,32	*132MB-4	1600	1,67	150	250	3SPZ	483	N
184	570	J31	5	1,34	1,32	*132MB-4	1600	1,57	150	236	3SPZ	494	T
194	541	J31	5	1,38	1,31	*132MB-4	1500	1,49	150	224	3SPZ	454	N
194	541	J31	5	1,38	1,33	*132MB-4	1600	1,49	150	224	3SPZ	504	T
205	512	J31	5	1,44	1,31	*132MB-4	1500	1,41	150	212	3SPZ	464	N
205	512	J31	5	1,44	1,33	*132MB-4	1600	1,41	150	212	3SPZ	514	T
218	483	J31	5	1,49	1,32	*132MB-4	1500	1,33	150	200	3SPZ	474	N
229	459	J31	5	1,55	1,32	*132MB-4	1500	1,27	150	190	3SPZ	482	N
242	435	J31	5	1,60	1,32	*132MB-4	1500	1,20	150	180	3SPZ	490	T
274	384	J31	5	1,74	1,01	*132MB-4	1500	1,06	170	180	2SPZ	474	N
13	10633	J110	20	1,33	1,39	*180LB-8	3150	2,68	224	600	3SPA	907	T
15	9870	J110	25	1,43	1,21	180L-6	3150	2,68	224	600	2SPA	907	T
16	8718	J110	25	1,62	1,22	180L-6	3000	2,37	224	530	2SPA	894	T
17	8301	J100	20	1,20	1,18	180L-6	3000	2,81	224	630	2SPA	803	T
17	8240	J100	25	1,21	1,20	180L-6	2800	2,23	224	500	2SPA	819	T
18	7893	J110	20	1,79	1,21	180L-6	3150	2,68	224	600	2SPA	907	T
20	7004	J100	25	1,43	1,21	180L-6	2650	1,90	224	425	2SPA	808	T
22	6592	J100	25	1,52	1,22	180L-6	2650	1,79	224	400	2SPA	829	T
22	6620	J100	15	1,51	1,18	180L-6	3000	2,81	224	630	2SPA	803	T
22	6588	J100	20	1,52	1,20	180L-6	2800	2,23	224	500	2SPA	819	T

15.0 kW

*High
efficiency
motor

SERIES J

POWER RATINGS V-BELT TRANSMISSIONS

15.0 kW

n2 rpm	T2 Nm	Gear unit	i	fbp SF	V-belt length SF	Motor	V-belt length mm	Pulley Ratio	Pulley D1	Pulley D2	Pulley type	C-C mm	Motor- mount type
26	5600	J100	20	1,79	1,21	180L-6	2650	1,90	224	425	2SPA	808	T
30	4827	J72	25	1,04	1,30	160M-2	2240	4,03	118	475	3SPZ	628	N
30	4827	J72	25	1,04	1,33	160M-2	2360	4,03	118	475	3SPZ	690	T
31	4573	J72	25	1,09	1,34	160M-2	2360	3,81	118	450	3SPZ	714	T
32	4530	J72	15	1,10	1,39	160L-4	2650	3,15	200	630	2SPA	636	N
33	4318	J72	25	1,16	1,31	160M-2	2120	3,60	118	425	3SPZ	614	N
33	4334	J72	15	1,15	1,19	180L-6	2500	2,01	224	450	2SPA	711	T
35	4064	J72	25	1,23	1,32	160M-2	2120	3,39	118	400	3SPZ	637	N
35	4093	J72	15	1,22	1,19	180L-6	2500	1,90	224	425	2SPA	732	T
35	4064	J72	25	1,23	1,35	160M-2	2240	3,39	118	400	3SPZ	698	T
40	3607	J72	25	1,39	1,33	160M-2	2000	3,01	118	355	3SPZ	616	N
40	3611	J72	15	1,38	1,19	180L-6	2360	1,67	224	375	2SPA	705	T
42	3404	J72	25	1,46	1,34	160M-2	2000	2,84	118	335	3SPZ	634	N
42	3404	J72	25	1,46	1,36	160M-2	2120	2,84	118	335	3SPZ	695	T
42	3419	J72	15	1,43	1,20	180L-6	2360	1,58	224	355	2SPA	721	T
45	3201	J72	25	1,53	1,37	160M-2	2120	2,67	118	315	3SPZ	712	T
47	3048	J72	25	1,59	1,34	160M-2	1900	2,54	118	300	3SPZ	614	N
50	2845	J72	25	1,66	1,34	160M-2	1900	2,37	118	280	3SPZ	631	N
50	2885	J72	15	1,61	1,30	160M-2	2240	4,03	118	475	3SPZ	628	N
50	2845	J72	25	1,66	1,36	160M-2	2000	2,37	118	280	3SPZ	682	T
50	2885	J72	15	1,61	1,33	160M-2	2360	4,03	118	475	3SPZ	690	T
50	2889	J72	15	1,61	1,20	180L-6	2240	1,34	224	300	2SPA	707	T
52	2733	J72	15	1,68	1,34	160M-2	2360	3,81	118	450	3SPZ	714	T
53	2723	J52	25	1,00	1,35	160M-2	1900	2,25	118	265	3SPZ	644	T
53	2719	J52	15	1,07	1,31	160M-2	2120	3,60	118	425	3SPZ	614	T
53	2696	J72	15	1,69	1,20	180L-6	2240	1,25	224	280	2SPA	723	T
56	2581	J72	15	1,75	1,31	160M-2	2120	3,60	118	425	3SPZ	614	N
56	2543	J72	25	1,80	1,03	160M-2	1900	2,12	132	280	2SPZ	621	N
56	2542	J72	25	1,80	1,02	160L-4	2120	1,06	265	280	1SPA	631	N
56	2559	J72	15	1,76	1,28	180L-6	2240	1,19	236	280	2SPA	714	T
56	2559	J52	15	1,13	1,32	160M-2	2120	3,39	118	400	3SPZ	637	T
56	2542	J52	15	1,80	1,03	160L-4	2240	1,06	265	280	1SPA	691	T
59	2425	J52	25	1,08	1,35	160M-2	1800	2,00	118	236	3SPZ	618	T
62	2302	J52	25	1,12	1,35	160M-2	1800	1,90	118	224	3SPZ	628	T
63	2271	J52	15	1,28	1,33	160M-2	2000	3,01	118	355	3SPZ	616	T
66	2179	J52	25	1,16	1,35	160M-2	1800	1,80	118	212	3SPZ	638	T
67	2143	J52	15	1,35	1,34	160M-2	2000	2,84	118	335	3SPZ	634	T
75	1920	J52	15	1,51	1,34	160M-2	1900	2,54	118	300	3SPZ	614	T
78	1837	J52	25	1,30	1,04	160M-2	1800	1,52	132	200	2SPZ	638	T
80	1792	J52	15	1,62	1,34	160M-2	1900	2,37	118	280	3SPZ	631	T
83	1732	J52	25	1,35	1,11	160M-2	1800	1,43	140	200	2SPZ	632	T
84	1696	J52	15	1,71	1,35	160M-2	1900	2,25	118	265	3SPZ	644	T
88	1628	J71	5	1,62	1,16	180L-6	2500	2,23	224	500	2SPA	666	N
89	1617	J52	25	1,41	1,20	160M-2	1800	1,33	150	200	2SPZ	624	T
90	1588	J100	5	1,59	1,20	180L-6	2650	2,12	224	475	2SPA	765	T
93	1546	J71	5	1,68	1,18	180L-6	2500	2,12	224	475	2SPA	689	T
94	1531	J71	5	1,69	1,39	160L-4	2650	3,15	200	630	2SPA	636	N
95	1516	J52	25	1,47	1,29	160M-2	1800	1,25	160	200	2SPZ	616	T
95	1505	J100	5	1,65	1,20	180L-6	2650	2,01	224	450	2SPA	787	T
99	1445	J32	15	1,01	1,39	160L-4	1700	0,95	190	200	2SPA	543	T
105	1362	J32	15	1,05	1,32	160M-2	1600	1,80	118	212	3SPZ	538	T
105	1369	J32	15	1,05	1,36	160L-4	1700	0,90	180	200	2SPA	551	T
108	1321	J51	5	1,38	1,36	160L-4	2240	2,65	200	530	2SPA	520	N
111	1285	J32	15	1,10	1,32	160M-2	1600	1,69	118	200	3SPZ	548	T
115	1246	J51	5	1,43	1,39	160L-4	2240	2,50	200	500	2SPA	549	N
117	1221	J32	15	1,14	1,33	160M-2	1600	1,61	118	190	3SPZ	556	T
124	1157	J32	15	1,18	1,33	160M-2	1600	1,53	118	180	3SPZ	564	T
128	1121	J51	5	1,54	1,40	160L-4	2120	2,25	200	450	2SPA	534	N
139	1034	J32	15	1,28	1,02	160M-2	1600	1,36	132	180	2SPZ	554	T
147	975	J32	15	1,33	1,09	160M-2	1600	1,29	140	180	2SPZ	548	T
157	910	J32	15	1,40	1,17	160M-2	1600	1,20	150	180	2SPZ	540	T
168	853	J32	15	1,46	1,26	160M-2	1600	1,13	160	180	2SPZ	532	T

*High
efficiency
motor

SERIES J

POWER RATINGS V-BELT TRANSMISSIONS

18.5 kW

n2 rpm	T2 Nm	Gear unit	i	fbp SF	V-belt length SF	Motor	V-belt length mm	Pulley Ratio	Pulley D1	Pulley D2	Pulley type	C-C mm	Motor- mount type
18	9725	J100	25	1,03	1,28	*180LB-6	2650	2,13	200	425	3SPA	826	T
18	9696	J100	20	1,03	1,26	*180LB-6	2800	2,65	200	530	3SPA	809	T
19	9192	J100	15	1,09	1,24	*180LB-6	3000	3,15	200	630	3SPA	819	T
19	9527	J100	25	1,05	1,30	200MLA-6	2650	2,13	200	425	3SPA	826	T
20	8967	J100	25	1,12	1,31	200MLA-6	2650	2,00	200	400	3SPA	847	T
20	8962	J100	20	1,12	1,29	200MLA-6	2800	2,50	200	500	3SPA	836	T
20	9005	J100	15	1,11	1,27	200MLA-6	3000	3,15	200	630	3SPA	819	T
20	8927	J100	25	1,12	1,29	180M-4	3000	2,97	212	630	2SPA	811	T
21	8577	J100	15	1,17	1,28	200MLA-6	3000	3,00	200	600	3SPA	847	T
21	8233	J100	20	1,21	1,27	*180LB-6	2650	2,25	200	450	3SPA	804	T
22	8123	J100	25	1,23	1,28	*180LB-6	2500	1,77	200	355	3SPA	810	T
23	7665	J100	25	1,30	1,29	*180LB-6	2500	1,67	200	335	3SPA	826	T
23	7775	J100	20	1,29	1,28	*180LB-6	2650	2,13	200	425	3SPA	826	T
23	7733	J100	15	1,29	1,26	*180LB-6	2800	2,65	200	530	3SPA	809	T
23	7614	J100	25	1,31	1,29	*160LB-4	2800	2,50	212	530	2SPA	801	T
23	7617	J100	20	1,31	1,30	200MLA-6	2650	2,13	200	425	3SPA	826	T
24	7510	J100	25	1,33	1,31	200MLA-6	2500	1,67	200	335	3SPA	826	T
24	7510	J100	25	1,33	1,30	180M-4	2800	2,50	212	530	2SPA	801	T
25	7061	J100	25	1,42	1,32	200MLA-6	2500	1,58	200	315	3SPA	843	T
25	7169	J100	20	1,39	1,31	200MLA-6	2650	2,00	200	400	3SPA	847	T
25	7147	J100	15	1,40	1,29	200MLA-6	2800	2,50	200	500	3SPA	836	T
25	7138	J100	20	1,40	1,29	180M-4	3000	2,97	212	630	2SPA	811	T
27	6495	J100	20	1,54	1,28	*180LB-6	2500	1,77	200	355	3SPA	810	T
27	6566	J100	15	1,52	1,27	*180LB-6	2650	2,25	200	450	3SPA	804	T
28	6201	J100	15	1,61	1,28	*180LB-6	2650	2,13	200	425	3SPA	826	T
28	6407	J100	25	1,56	1,28	*180LB-6	2360	1,40	200	280	3SPA	801	T
29	6004	J100	20	1,67	1,31	200MLA-6	2500	1,67	200	335	3SPA	826	T
29	6129	J100	20	1,63	1,29	*180LB-6	2500	1,67	200	335	3SPA	826	T
29	6064	J100	25	1,65	1,28	*180LB-6	2360	1,33	200	265	3SPA	813	T
29	6088	J100	20	1,64	1,29	*160LB-4	2800	2,50	212	530	2SPA	801	T
29	6075	J100	15	1,65	1,30	200MLA-6	2650	2,13	200	425	3SPA	826	T
29	6005	J100	20	1,67	1,30	180M-4	2800	2,50	212	530	2SPA	801	T
31	5646	J100	20	1,77	1,32	200MLA-6	2500	1,58	200	315	3SPA	843	T
31	5718	J100	15	1,75	1,31	200MLA-6	2650	2,00	200	400	3SPA	847	T
31	5665	J100	20	1,77	1,31	180M-4	2800	2,36	212	500	2SPA	827	T
31	5693	J100	15	1,76	1,29	180M-4	3000	2,97	212	630	2SPA	811	T
35	4987	J72	25	1,00	1,26	*160LB-4	2120	1,67	212	355	2SPA	610	N
35	5014	J72	15	1,00	1,26	*180LB-6	2360	1,88	200	375	3SPA	722	T
36	4912	J72	15	1,02	1,28	200MLA-6	2360	1,88	200	375	3SPA	722	T
36	4919	J72	25	1,02	1,31	180M-4	2360	1,67	212	355	2SPA	730	T
38	4706	J72	25	1,06	1,27	*160LB-4	2120	1,58	212	335	2SPA	627	N
38	4650	J72	15	1,07	1,29	200MLA-6	2360	1,77	200	355	3SPA	739	T
38	4706	J72	25	1,06	1,29	*160LB-4	2240	1,58	212	335	2SPA	687	T
38	4701	J72	15	1,06	1,25	*160LB-4	2650	2,64	212	560	2SPA	696	T
40	4425	J72	25	1,13	1,28	*160LB-4	2120	1,49	212	315	2SPA	643	N
40	4365	J72	25	1,14	1,31	180M-4	2240	1,49	212	315	2SPA	703	T
40	4389	J72	15	1,13	1,28	180M-4	2650	2,50	212	530	2SPA	724	T
40	4425	J72	25	1,13	1,29	*160LB-4	2240	1,49	212	315	2SPA	703	T
42	4212	J72	15	1,16	1,26	*180LB-6	2240	1,58	200	315	3SPA	712	T
43	4157	J72	25	1,19	1,31	180M-4	2240	1,42	212	300	2SPA	716	T
44	4011	J72	15	1,20	1,27	*180LB-6	2240	1,50	200	300	3SPA	725	T
44	3988	J72	15	1,21	1,27	*160LB-4	2500	2,24	212	475	2SPA	697	T
45	3933	J72	25	1,25	1,27	*160LB-4	2000	1,32	212	280	2SPA	612	N
45	3930	J72	15	1,22	1,29	200MLA-6	2240	1,50	200	300	3SPA	725	T
46	3880	J72	25	1,26	1,31	180M-4	2240	1,32	212	280	2SPA	732	T
47	3726	J72	15	1,27	1,29	180M-4	2500	2,12	212	450	2SPA	719	T
48	3668	J72	15	1,28	1,29	200MLA-6	2240	1,40	200	280	3SPA	741	T
48	3672	J72	25	1,31	1,40	180M-4	2240	1,25	224	280	2SPA	723	T
50	3532	J72	15	1,32	1,36	*180LB-6	2240	1,32	212	280	3SPA	732	T
51	3460	J72	15	1,33	1,39	200MLA-6	2240	1,32	212	280	3SPA	732	T
53	3358	J72	15	1,36	1,28	*160LB-4	2360	1,89	212	400	2SPA	692	T
56	3173	J72	15	1,42	1,03	*180LB-6	2240	1,19	236	280	2SPA	714	T
56	3148	J72	15	1,43	1,29	*160LB-4	2360	1,77	212	375	2SPA	713	T
57	3105	J72	15	1,44	1,30	180M-4	2360	1,77	212	375	2SPA	713	T

*High efficiency motor

SERIES J

POWER RATINGS V-BELT TRANSMISSIONS

18.5 kW

n2 rpm	T2 Nm	Gear unit	i	fbp SF	V-belt length SF	Motor	V-belt length mm	Pulley Ratio	Pulley D1	Pulley D2	Pulley type	C-C mm	Motor- mount type
59	2995	J72	15	1,48	1,10	*180LB-6	2240	1,12	250	280	2SPA	703	T
60	2940	J72	15	1,50	1,31	180M-4	2360	1,67	212	355	2SPA	730	T
63	2812	J72	15	1,54	1,29	*160LB-4	2240	1,58	212	335	2SPA	687	T
63	2786	J52	15	1,04	1,28	*160LB-4	2120	1,49	212	315	2SPA	643	T
64	2768	J72	15	1,56	1,20	200MLA-6	2360	1,06	265	280	2SPA	751	T
67	2620	J72	15	1,62	1,26	200MLA-6	2360	1,00	280	280	2SPA	739	T
67	2644	J72	15	1,61	1,29	*160LB-4	2240	1,49	212	315	2SPA	703	T
68	2608	J72	15	1,63	1,31	180M-4	2240	1,49	212	315	2SPA	703	T
68	2588	J72	25	1,67	1,07	160L-2	2120	1,75	160	280	2SPZ	711	T
71	2484	J72	15	1,68	1,31	180M-4	2240	1,42	212	300	2SPA	716	T
71	2477	J52	15	1,17	1,27	*160LB-4	2000	1,32	212	280	2SPA	612	T
73	2436	J72	25	1,74	1,12	160L-2	2000	1,65	170	280	2SPZ	643	N
73	2436	J72	25	1,74	1,14	160L-2	2120	1,65	170	280	2SPZ	704	T
75	2344	J52	15	1,24	1,27	*160LB-4	2000	1,25	212	265	2SPA	624	T
76	2319	J72	15	1,77	1,31	180M-4	2240	1,32	212	280	2SPA	732	T
80	2211	J52	15	1,31	1,27	*160LB-4	2000	1,18	212	250	2SPA	636	T
82	2147	J71	5	1,26	1,24	*180LB-6	2500	2,38	200	475	3SPA	706	T
87	2034	J71	5	1,30	1,23	*180LB-6	2360	2,25	200	450	3SPA	657	N
92	1921	J71	5	1,35	1,24	*180LB-6	2360	2,13	200	425	3SPA	679	N
92	1921	J71	5	1,35	1,24	*180LB-6	2360	2,13	200	425	3SPA	679	T
94	1875	J52	15	1,54	1,23	*160LB-4	1900	1,00	212	212	2SPA	616	T
95	1869	J52	25	1,19	1,04	160L-2	1800	1,25	160	200	2SPZ	616	T
95	1857	J100	5	1,34	1,27	*180LB-6	2500	2,00	200	400	3SPA	771	T
96	1833	J51	5	1,03	1,17	*160LB-4	2500	2,97	212	630	2SPA	548	N
98	1808	J71	5	1,41	1,25	*180LB-6	2360	2,00	200	400	3SPA	701	T
100	1763	J71	5	1,43	1,25	180M-4	2800	2,97	212	630	2SPA	707	T
100	1769	J52	15	1,62	1,23	*160LB-4	1900	0,94	200	212	2SPA	626	T
104	1695	J71	5	1,47	1,24	*180LB-6	2240	1,88	200	375	3SPA	662	N
104	1703	J71	5	1,47	1,23	*160LB-4	2650	2,83	212	600	2SPA	658	N
104	1703	J71	5	1,47	1,23	*160LB-4	2650	2,83	212	600	2SPA	658	T
104	1706	J100	5	1,42	1,30	200MLA-6	2500	1,88	200	375	3SPA	793	T
105	1680	J71	5	1,48	1,24	180M-4	2650	2,83	212	600	2SPA	658	N
108	1629	J51	5	1,12	1,19	*160LB-4	2360	2,64	212	560	2SPA	545	N
108	1629	J51	5	1,12	1,22	*160LB-4	2500	2,64	212	560	2SPA	618	T
109	1615	J100	5	1,47	1,31	200MLA-6	2500	1,77	200	355	3SPA	810	T
110	1605	J71	5	1,53	1,25	*180LB-6	2240	1,77	200	355	3SPA	679	N
110	1605	J71	5	1,53	1,25	*180LB-6	2240	1,77	200	355	3SPA	679	T
112	1574	J52	25	1,34	1,25	160L-2	1900	1,05	190	200	2SPZ	643	T
113	1568	J71	5	1,55	1,26	180M-4	2650	2,64	212	560	2SPA	696	T
114	1555	J100	5	1,51	1,27	*180LB-6	2360	1,67	200	335	3SPA	756	T
117	1514	J71	5	1,59	1,34	*180LB-6	2240	1,67	212	355	3SPA	670	N
117	1504	J71	5	1,59	1,24	*160LB-4	2500	2,50	212	530	2SPA	647	N
121	1455	J51	5	1,21	1,21	*160LB-4	2240	2,36	212	500	2SPA	541	N
121	1462	J100	5	1,57	1,28	*180LB-6	2360	1,58	200	315	3SPA	773	T
121	1457	J100	5	1,58	1,28	*160LB-4	2650	2,36	212	500	2SPA	751	T
121	1455	J51	5	1,21	1,23	*160LB-4	2360	2,36	212	500	2SPA	603	T
125	1419	J71	5	1,66	1,26	*160LB-4	2500	2,36	212	500	2SPA	675	T
126	1400	J71	5	1,67	1,27	180M-4	2500	2,36	212	500	2SPA	675	N
126	1400	J71	5	1,67	1,27	180M-4	2500	2,36	212	500	2SPA	675	T
127	1393	J100	5	1,62	1,28	*180LB-6	2360	1,50	200	300	3SPA	785	T
129	1364	J100	5	1,65	1,30	200MLA-6	2360	1,50	200	300	3SPA	785	T
129	1366	J100	5	1,64	1,30	180M-4	2650	2,24	212	475	2SPA	773	T
130	1360	J71	5	1,70	1,02	*180LB-6	2240	1,50	236	355	2SPA	652	N
133	1330	J71	5	1,73	1,28	180M-4	2500	2,24	212	475	2SPA	697	T
135	1309	J51	5	1,29	1,21	*160LB-4	2120	2,12	212	450	2SPA	526	N
138	1277	J71	5	1,78	1,26	*160LB-4	2360	2,12	212	450	2SPA	648	N
138	1284	J71	5	1,77	1,10	*180LB-6	2360	1,42	250	355	2SPA	702	T
139	1273	J100	5	1,72	1,31	200MLA-6	2360	1,40	200	280	3SPA	801	T
143	1237	J51	5	1,34	1,23	*160LB-4	2120	2,00	212	425	2SPA	548	N
143	1239	J100	5	1,76	1,29	*160LB-4	2500	2,00	212	425	2SPA	741	T
143	1237	J51	5	1,34	1,25	*160LB-4	2240	2,00	212	425	2SPA	610	T
162	1091	J51	5	1,46	1,23	*160LB-4	2000	1,77	212	375	2SPA	532	N
162	1091	J51	5	1,46	1,25	*160LB-4	2120	1,77	212	375	2SPA	593	T
168	1052	J32	15	1,18	1,02	160L-2	1600	1,13	160	180	2SPZ	532	T

*High
efficiency
motor

SERIES J

POWER RATINGS V-BELT TRANSMISSIONS

18.5 kW

22.0 kW

n2 rpm	T2 Nm	Gear unit	i	fbp SF	V-belt length SF	Motor	V-belt length mm	Pulley Ratio	Pulley D1	Pulley D2	Pulley type	C-C mm	Motor- mount type
171	1033	J51	5	1,51	1,24	*160LB-4	2000	1,67	212	355	2SPA	549	N
171	1033	J51	5	1,51	1,26	*160LB-4	2120	1,67	212	355	2SPA	610	T
181	978	J51	5	1,57	1,33	*160LB-4	2000	1,58	224	355	2SPA	540	N
181	978	J51	5	1,57	1,35	*160LB-4	2120	1,58	224	355	2SPA	601	T
31	6855	J100	20	1,46	1,32	180L-4	3000	2,40	250	600	2SPA	813	T
37	5713	J100	20	1,75	1,34	180L-4	2800	2,00	250	500	2SPA	800	T
37	5620	J100	25	1,78	1,34	*160LB-2	2650	3,13	160	500	3SPZ	787	T
42	4946	J72	25	1,00	1,29	*160LB-2	2240	2,81	160	450	3SPZ	623	N
42	4960	J72	25	1,00	1,33	180L-4	2360	1,42	250	355	2SPA	702	T
42	4946	J72	25	1,00	1,31	*160LB-2	2360	2,81	160	450	3SPZ	685	T
45	4655	J72	25	1,05	1,33	180M-2	2360	2,66	160	425	3SPZ	707	T
45	4681	J72	25	1,05	1,34	180L-4	2360	1,34	250	335	2SPA	718	T
45	4671	J72	25	1,05	1,32	*160LB-2	2360	2,66	160	425	3SPZ	707	T
48	4381	J72	25	1,10	1,34	180M-2	2360	2,50	160	400	3SPZ	729	T
48	4401	J72	25	1,09	1,34	180L-4	2360	1,26	250	315	2SPA	735	T
50	4175	J72	15	1,11	1,32	180L-4	2650	2,00	250	500	2SPA	724	T
51	4122	J72	25	1,14	1,31	*160LB-2	2120	2,34	160	375	3SPZ	630	N
51	4122	J72	25	1,14	1,33	*160LB-2	2240	2,34	160	375	3SPZ	691	T
54	3888	J72	25	1,19	1,34	180M-2	2240	2,22	160	355	3SPZ	708	T
54	3912	J72	25	1,19	1,33	180L-4	2240	1,12	250	280	2SPA	703	T
54	3902	J72	25	1,19	1,34	*160LB-2	2240	2,22	160	355	3SPZ	708	T
57	3669	J72	25	1,24	1,35	180M-2	2240	2,09	160	335	3SPZ	725	T
59	3549	J72	15	1,25	1,33	180L-4	2500	1,70	250	425	2SPA	714	T
61	3462	J72	25	1,29	1,32	*160LB-2	2000	1,97	160	315	3SPZ	621	N
61	3462	J72	25	1,29	1,33	*160LB-2	2120	1,97	160	315	3SPZ	682	T
63	3309	J72	15	1,31	1,01	200MLB-6	2360	1,06	265	280	2SPA	751	T
63	3340	J72	15	1,30	1,34	180L-4	2500	1,60	250	400	2SPA	735	T
64	3297	J72	25	1,34	1,32	*160LB-2	2000	1,88	160	300	3SPZ	634	N
64	3284	J72	15	1,31	1,28	*160LB-2	2360	3,13	160	500	3SPZ	638	N
64	3273	J72	15	1,32	1,31	180M-2	2500	3,13	160	500	3SPZ	710	T
64	3297	J72	25	1,34	1,34	*160LB-2	2120	1,88	160	300	3SPZ	694	T
64	3284	J72	15	1,31	1,31	*160LB-2	2500	3,13	160	500	3SPZ	710	T
67	3132	J72	15	1,36	1,06	200MLB-6	2360	1,00	280	280	2SPA	739	T
68	3109	J72	15	1,37	1,33	180M-2	2500	2,97	160	475	3SPZ	733	T
68	3077	J72	25	1,40	1,35	*160LB-2	2120	1,75	160	280	3SPZ	711	T
69	3067	J72	25	1,41	1,35	180M-2	2120	1,75	160	280	3SPZ	711	T
71	2956	J72	15	1,42	1,29	*160LB-2	2240	2,81	160	450	3SPZ	623	N
71	2964	J72	15	1,41	1,33	180L-4	2360	1,42	250	355	2SPA	702	T
71	2956	J72	15	1,42	1,31	*160LB-2	2360	2,81	160	450	3SPZ	685	T
75	2797	J72	15	1,47	1,34	180L-4	2360	1,34	250	335	2SPA	718	T
75	2792	J72	15	1,47	1,32	*160LB-2	2360	2,66	160	425	3SPZ	707	T
76	2782	J72	15	1,48	1,33	180M-2	2360	2,66	160	425	3SPZ	707	T
77	2736	J72	25	1,52	1,02	*160LB-2	2120	1,56	180	280	2SPZ	696	T
80	2619	J72	15	1,54	1,34	180M-2	2360	2,50	160	400	3SPZ	729	T
80	2630	J72	15	1,54	1,34	180L-4	2360	1,26	250	315	2SPA	735	T
81	2592	J72	25	1,58	1,06	*160LB-2	2000	1,47	190	280	2SPZ	628	N
81	2595	J52	15	1,12	1,31	*160LB-2	2120	2,34	160	375	3SPZ	630	T
81	2592	J72	25	1,58	1,07	*160LB-2	2120	1,47	190	280	2SPZ	689	T
85	2463	J72	15	1,61	1,31	*160LB-2	2120	2,34	160	375	3SPZ	630	N
85	2463	J72	15	1,61	1,33	*160LB-2	2240	2,34	160	375	3SPZ	691	T
90	2324	J72	15	1,67	1,34	180M-2	2240	2,22	160	355	3SPZ	708	T
90	2338	J72	15	1,67	1,33	180L-4	2240	1,12	250	280	2SPA	703	T
90	2332	J72	15	1,67	1,34	*160LB-2	2240	2,22	160	355	3SPZ	708	T
95	2223	J52	25	1,00	1,32	*160LB-2	1800	1,25	160	200	3SPZ	616	T
96	2193	J72	15	1,74	1,35	180M-2	2240	2,09	160	335	3SPZ	725	T
96	2180	J52	15	1,32	1,32	*160LB-2	2000	1,97	160	315	3SPZ	621	T
101	2076	J52	15	1,38	1,32	*160LB-2	2000	1,88	160	300	3SPZ	634	T
112	1872	J52	25	1,13	1,05	*160LB-2	1900	1,05	190	200	2SPZ	643	T
115	1834	J52	15	1,53	1,32	*160LB-2	1900	1,66	160	265	3SPZ	613	T
118	1778	J71	5	1,35	1,28	180L-4	2800	2,52	250	630	2SPA	681	N
118	1778	J71	5	1,35	1,28	180L-4	2800	2,52	250	630	2SPA	681	T
121	1730	J52	15	1,61	1,32	*160LB-2	1900	1,56	160	250	3SPZ	626	T
129	1633	J52	15	1,69	1,33	*160LB-2	1900	1,48	160	236	3SPZ	637	T

*High efficiency motor

SERIES J

POWER RATINGS V-BELT TRANSMISSIONS

22.0 kW

30.0 kW

37.0 kW

*High efficiency motor

n2 rpm	T2 Nm	Gear unit	i	fbp SF	V-belt length SF	Motor	V-belt length mm	Pulley Ratio	Pulley D1	Pulley D2	Pulley type	C-C mm	Motor-mount type
133	1581	J71	5	1,46	1,29	180L-4	2650	2,24	250	560	2SPA	670	N
137	1537	J100	5	1,44	1,33	180L-4	2800	2,12	250	530	2SPA	774	T
140	1496	J71	5	1,51	1,30	180L-4	2650	2,12	250	530	2SPA	697	T
157	1341	J71	5	1,62	1,31	180L-4	2500	1,90	250	475	2SPA	670	N
161	1305	J100	5	1,60	1,34	180L-4	2650	1,80	250	450	2SPA	768	T
165	1270	J71	5	1,68	1,32	180L-4	2500	1,80	250	450	2SPA	692	T
168	1251	J32	15	1,00	1,28	*160LB-2	1600	1,13	160	180	3SPZ	532	T
171	1232	J100	5	1,66	1,35	180L-4	2650	1,70	250	425	2SPA	789	T
32	8981	J100	25	1,11	1,07	200MLA-2	3000	3,71	170	630	2SPA	839	T
36	8010	J100	25	1,25	1,06	*180LB-2	2800	3,29	170	560	2SPA	802	T
38	7555	J100	25	1,32	1,08	200MLA-2	2800	3,12	170	530	2SPA	830	T
38	7581	J100	25	1,32	1,08	*180LB-2	2800	3,12	170	530	2SPA	830	T
40	7181	J100	20	1,39	1,07	200MLA-2	3000	3,71	170	630	2SPA	839	T
41	6987	J100	20	1,43	1,00	200MLA-4	2800	1,80	250	450	2SPA	843	T
42	6794	J100	25	1,47	1,08	*180LB-2	2650	2,79	170	475	2SPA	803	T
45	6415	J100	25	1,56	1,09	200MLA-2	2650	2,65	170	450	2SPA	825	T
45	6437	J100	25	1,55	1,08	*180LB-2	2650	2,65	170	450	2SPA	825	T
45	6405	J100	20	1,56	1,06	*180LB-2	2800	3,29	170	560	2SPA	802	T
47	6059	J100	25	1,65	1,09	200MLA-2	2650	2,50	170	425	2SPA	847	T
47	6041	J100	20	1,66	1,08	200MLA-2	2800	3,12	170	530	2SPA	830	T
47	6061	J100	20	1,65	1,08	*180LB-2	2800	3,12	170	530	2SPA	830	T
49	5823	J100	20	1,72	1,00	200MLA-4	2650	1,50	250	375	2SPA	831	T
50	5727	J100	15	1,75	1,07	200MLA-2	3000	3,71	170	630	2SPA	839	T
51	5573	J100	15	1,79	1,00	200MLA-4	2800	1,80	250	450	2SPA	843	T
65	4391	J72	25	1,00	1,08	200MLA-2	2240	1,85	170	315	2SPA	735	T
65	4406	J72	25	1,00	1,08	*180LB-2	2240	1,85	170	315	2SPA	735	T
67	4270	J72	15	1,00	1,08	*200MLC-6	2360	1,00	280	280	2SPB	739	T
69	4182	J72	25	1,03	1,08	200MLA-2	2240	1,76	170	300	2SPA	747	T
69	4179	J72	15	1,01	1,05	*180LB-2	2500	2,94	170	500	2SPA	704	T
72	3957	J72	15	1,05	1,06	200MLA-2	2500	2,79	170	475	2SPA	727	T
72	3970	J72	15	1,05	1,06	*180LB-2	2500	2,79	170	475	2SPA	727	T
73	3916	J72	25	1,08	1,07	*180LB-2	2120	1,65	170	280	2SPA	704	T
76	3749	J72	15	1,09	1,07	200MLA-2	2500	2,65	170	450	2SPA	749	T
81	3552	J72	15	1,13	1,06	*180LB-2	2360	2,50	170	425	2SPA	700	T
82	3492	J72	25	1,17	1,24	200MLA-2	2240	1,47	190	280	2SPA	749	T
86	3332	J72	15	1,19	1,07	200MLA-2	2360	2,35	170	400	2SPA	722	T
86	3344	J72	15	1,18	1,07	*180LB-2	2360	2,35	170	400	2SPA	722	T
92	3124	J72	15	1,24	1,08	200MLA-2	2360	2,21	170	375	2SPA	744	T
96	2998	J72	15	1,28	1,05	200MLA-4	2360	1,06	265	280	2SPA	751	T
97	2967	J72	15	1,29	1,07	*180LB-2	2240	2,09	170	355	2SPA	701	T
101	2837	J72	15	1,33	1,10	200MLA-4	2360	1,00	280	280	2SPA	739	T
102	2800	J72	15	1,34	1,07	*180LB-2	2240	1,97	170	335	2SPA	718	T
109	2624	J72	15	1,40	1,08	200MLA-2	2240	1,85	170	315	2SPA	735	T
109	2633	J72	15	1,40	1,08	*180LB-2	2240	1,85	170	315	2SPA	735	T
115	2499	J72	15	1,45	1,08	200MLA-2	2240	1,76	170	300	2SPA	747	T
122	2340	J72	15	1,52	1,07	*180LB-2	2120	1,65	170	280	2SPA	704	T
137	2087	J72	15	1,64	1,24	200MLA-2	2240	1,47	190	280	2SPA	749	T
182	1576	J100	5	1,27	1,00	200MLA-4	2650	1,60	250	400	2SPA	810	T
217	1320	J100	5	1,43	1,00	200MLA-4	2500	1,34	250	335	2SPA	789	T
221	1294	J71	5	1,50	1,04	*180LB-4	2360	1,34	265	355	2SPA	691	T
231	1241	J100	5	1,49	1,00	200MLA-4	2500	1,26	250	315	2SPA	805	T
234	1224	J71	5	1,56	1,10	*180LB-4	2360	1,27	280	355	2SPA	679	N
234	1224	J71	5	1,56	1,10	*180LB-4	2360	1,27	280	355	2SPA	679	T
251	1143	J71	5	1,63	1,19	*180LB-4	2360	1,18	300	355	2SPA	664	
263	1088	J71	5	1,68	1,25	*180LB-4	2360	1,13	315	355	2SPA	653	N
280	1023	J71	5	1,75	1,34	*180LB-4	2500	1,06	335	355	2SPA	707	T
94	3749	J72	15	1,02	1,26	*200MLB-4	2360	1,07	280	300	2SPB	724	T
101	3499	J72	15	1,08	1,23	*200MLB-4	2360	1,00	280	280	2SPB	739	T
327	1081	J100	5	1,52	1,23	225SMA-4	2500	0,89	250	280	2SPB	833	T

SERIES J

DIMENSIONS FOR THREADED HOLES AT GEARHOUSE SIDES

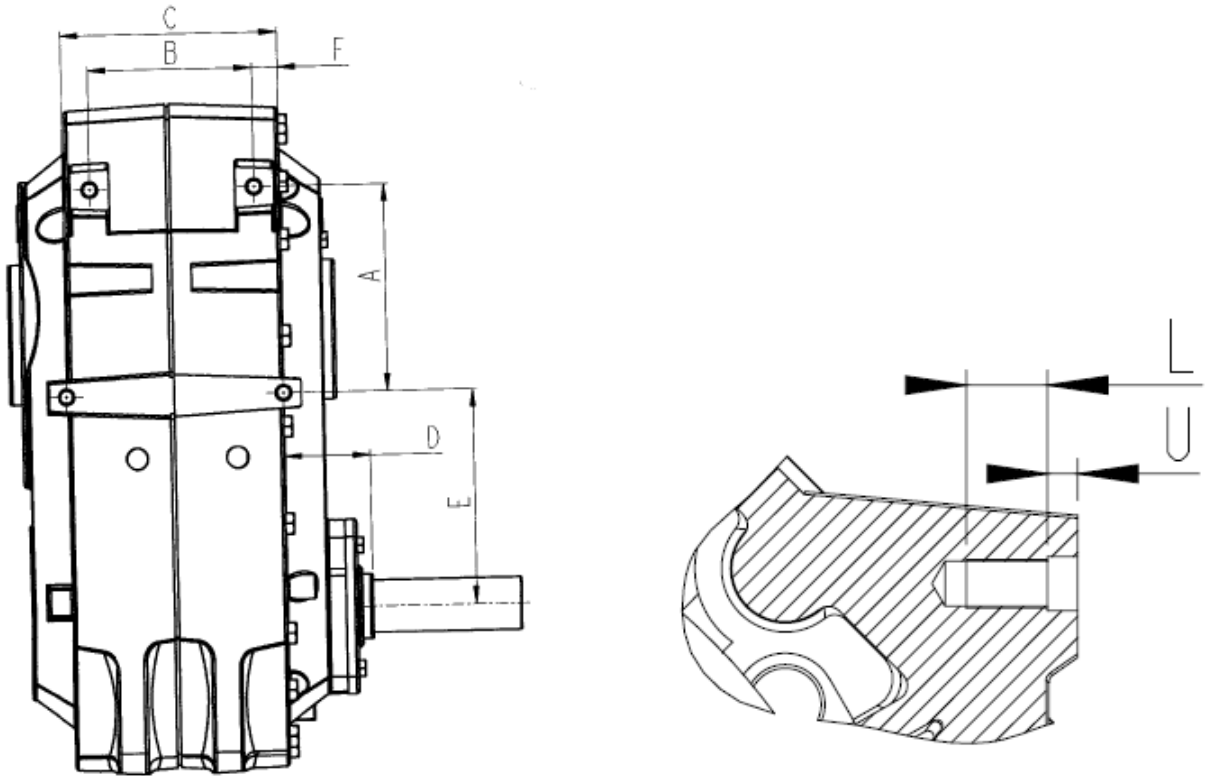

	A	B	C	D	E	F	L	U	THREAD
J100	217	120	160	88,5	163	20	27	10	M16

SERIES J

OUTPUT OPTIONS

Enter bore diameter in columns 10, 11 & 12

eg

0	3	5
1	2	0

Hollow shaft bores KIBO Column 9 entry

K

Gear size	Standard dimensions	Smaller dimensions *				xx	
J11A / 12A	35	30					
J11B / 12B	45	40	35				
J21A / J22A	45	40	35				
J21B / J22B	55	50	45				
J31A / J32A	55	50	45	40			
J31B / J32B	65	60	55				
J51A / J52A	60	55	50	45			
J51B / J52B	75	70	65	60			
J71A / J72A	70	65	60	55			
J71B / J72B	85	80	75	70			
J100 yy	100	95	90	85	80		

* Other dimensions on request.

xx Smallest possible diameter for inner diameter of Tapered bush without getting other total length of Hollow shaft/ Washer. For smaller dimensions please contact our Application Team.

yy Please note that when Gear sizes J100 is used as replacement gears for older units, a special kit for increasing machine shaft length is needed. Please advise when ordering size J100.

Shaft bushings

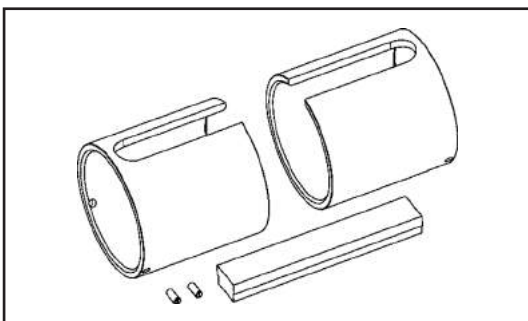

For shaft diameters varying from standard the following shaft bushings are available. Diameters not indicated may be supplied on request.

Size	Hollow Bore	Customer shaft diameter *			
J11 / 12A	35	30	25		
J11 / 12B	45	40	35	30	
J21 / 22A	45	40	35		
J21 / 22B	55	50	45	40	
J31 / 32A	55	50	45	40	
J31 / 32B	65	60	55	50	
J51 / 52A	60	55	50	40	
J51 / 52B	75	70	65	60	
J71 / 72A	70	65	60	55	
J71 / 72B	85	80	75	70	
J100	100	90	85	80	70

*Key and locking screws are supplied with each set of bushings.

SERIES J

MACHINE SHAFT DIMENSIONS FOR STANDARD HOLLOW SHAFT

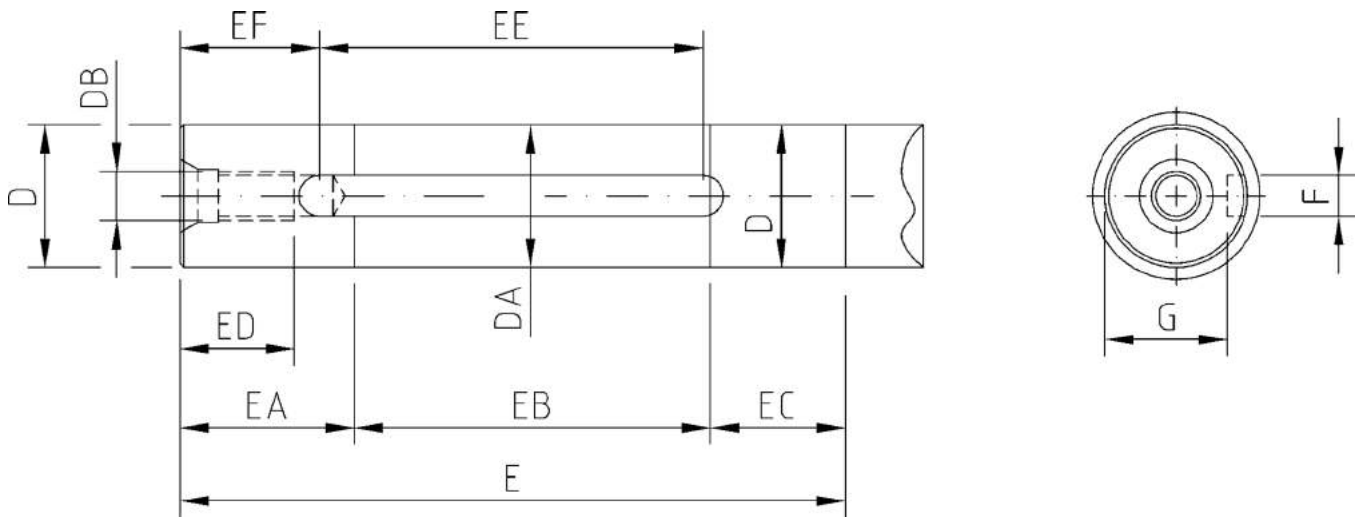

Column 9 entry



	D ¹⁾	DA ²⁾	DB ⁷⁾	E	EA	EB	EC	ED	EE	EF	F ³⁾	G
J12, 11	35	35	M12	115	30	50	35	28	95	10	10	30
	45	45	M16	115	30	50	35	36	95	10	14	39.5
J22, 21	45	45	M16	132	40	47	45	36	108	12	14	39.5
	55	55	M16	132	40	47	45	36	108	12	16	49
J32, 31	55	55	M16	143	45	48	50	36	117	13	16	49
	65	65	M16	143	45	48	50	36	117	13	18	58
J52, 51	60	60	M20	158	50	53	55	42	130	14	18	53
	75	75	M20	158	50	53	55	42	130	14	20	67.5
J72, 71	70	70	M20	168	55	53	60	42	138	15	20	62.5
	85	85	M20	168	55	53	60	42	138	15	22	76
J100	100	100	M24	248	60	125	63	50	141	40	28	90

Foot notes

- 1) ISO js6
- 2) ISO d10
- 3) ISO P9
- 7) Acc. to DIN 332

SERIES J

MACHINE SHAFT DIMENSIONS FOR KIBO STANDARD HOLLOW SHAFT

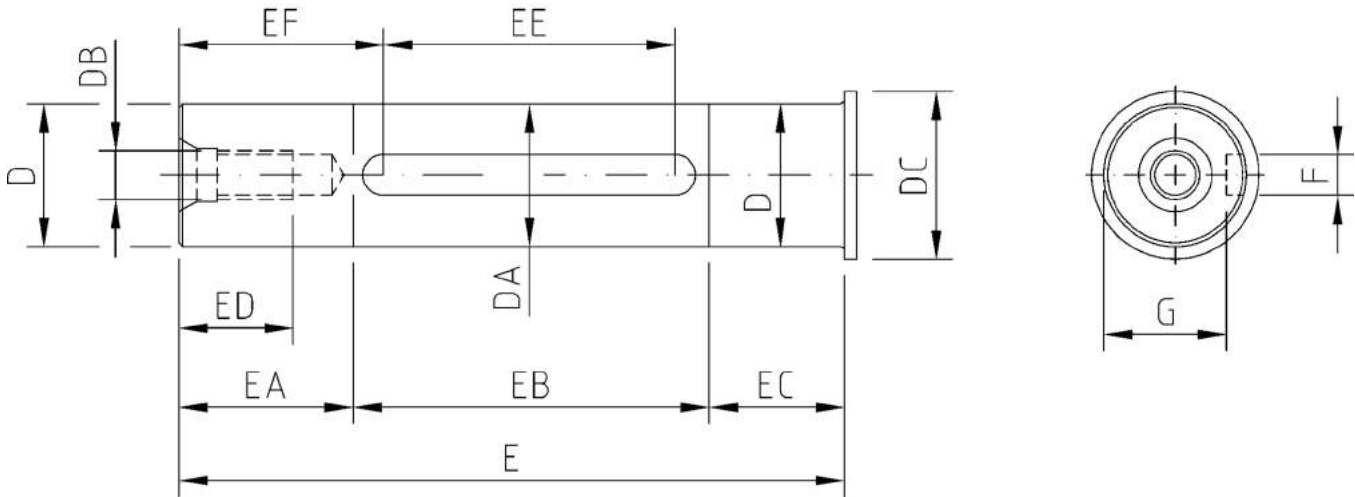

Column 9 entry

K

	D ⁶⁾	DA ²⁾	DB ⁷⁾	E	EA	EB	EC	ED	EE	EF	F ³⁾	G	D _{cmax} ⁸⁾	R _{max}
J12, 11	35	35	M12	137	40	57	40	28	32	51	10	30	42	1.6
	45	45	M16	137	40	57	40	36	25	41	14	39.5	51	1.6
J22, 21	45	45	M16	157	50	57	50	36	40	57	14	39.5	51	1.6
	55	55	M20	157	50	57	50	42	28	57	16	49	61	1.6
J32, 31	55	55	M20	172	58	56	58	42	40	62	16	49	61	1.6
	65	65	M20	172	58	56	58	42	40	52	18	58	76	1.6
J52, 51	60	60	M20	189	61	67	61	42	40	69	18	53	71	2.0
	75	75	M20	189	61	67	61	42	30	69	20	67.5	86	2.0
J72, 71	70	70	M20	203	67	69	67	42	56	64	20	62.5	81	2.0
	85	85	M20	203	67	69	67	42	45	62	22	76	96	2.0
J100	100	100	M24	296	61	152	83	50	141	66	28	90	116.5	2.0

Foot notes

- 2) ISO d10
- 3) ISO P9
- 6) ISO h8
- 7) Acc. to DIN332
- 8) Only for free-going nut

SERIES J

MACHINE SHAFT DIMENSIONS FOR SHRINK DISC STANDARD HOLLOW SHAFT

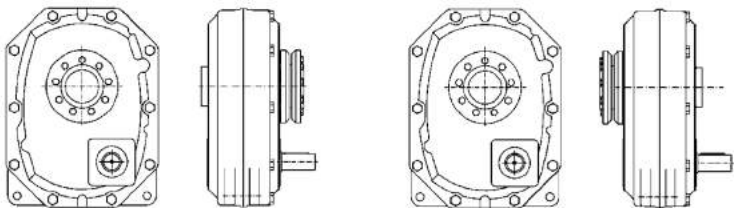
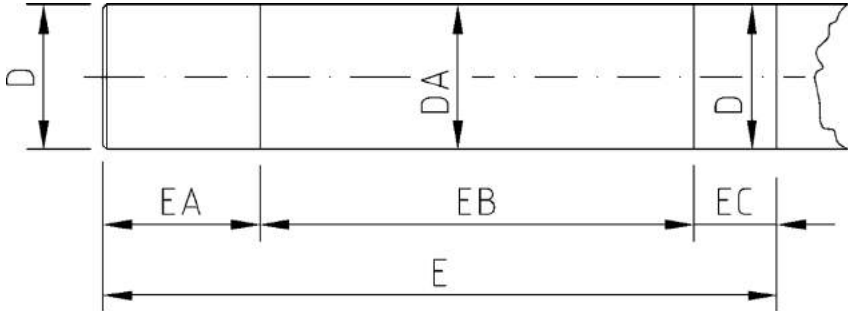

ST - Column 9 entry

S

STX - Column 9 entry

X

	D ⁴⁾	DA ²⁾	E	EA	EB	EC	Rel ⁵⁾
J12, 11	*)						
J22, 21	*)						
J32, 31	*)						
J52, 51	*)						
J72, 71	*)						
J100	100	100	345	85	200	60	310

Foot notes

- 2) ISO d10
- 4) ISO h6
- 5) Material yield limit N/mm²
- *) On request

SPEED REDUCER WITH KIBO TAPERED BUSHES, 1 FIXING BOLT

Mounting

For correct mounting of speed reducer it is important that both bushings get the same squeezing force.

1. Mount the inner bushing with the nut in its outer position. The bushing should be mounted against the shoulder or circlip. Where the shoulder should not exceed inside diameter of nut.
2. Put the key in the keyway.
3. Mount the reducer on the machine-shaft and press it against the inner bushing
4. Mount the outer bushing with the nut in its inner position. Check that the bushing is not squeezed but the nut is in contact with the shaft sleeve.
5. Mount the washer with its bolt. Tighten the bolt with correct torque. The inner bushing is now locked.
6. Loosen the bolt, so the outer bushing is loose. Turn the nut on the bushing, in its outer position.
7. Tighten the bolt once again with correct torque. The outer bushing is now locked.
The thicker washer may be changed to the thinner one in order to gain more space at the hollow shaft end. The thinner washer should be tightened with a torque of 25% of the value given in the table below.
8. Screw the nuts against the hollow shaft by hand, mounting is completed.

Dismounting

- Loosen the bolt and take away the washer.
- Pull out the outer bushing with the nut, by turning the nut with an adequate tool. Take out the bushing.
- Press the reducer from the inner bushing with the nut, dismounting is completed.

Tightening Torque

Size	Hollow shaft \varnothing	Screw	Tightening torque (Nm)
J12	35	M12	53
J12	45	M16	59
J22	45	M16	130
J22	55	M20	110
J32	55	M20	150
J32	65	M20	120
J52	60	M20	200
J52	75	M20	180
J72	70	M20	290
J72	85	M20	170
J100	100	M24	510

NOTE:

If reducer is mounted in a corrosive environment, ensure that machine shaft bushings and nuts are oiled or greased.

Do NOT use grease based on molybdendisulfide.

Advantages with KIBO taper bushes

- Simple design
- Easy to mount
- Easy to dismount, built in puller function
- Tapered bushes assure a safe mounting
- Reduces risk for shearing of key
- Bushings for different dimensions available

SERIES J

SPEED REDUCER WITH KIBO TAPERED BUSHES, 1 FIXING BOLT

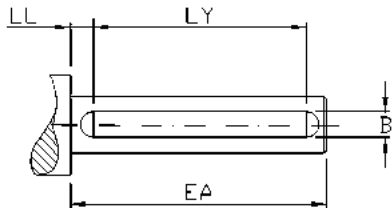
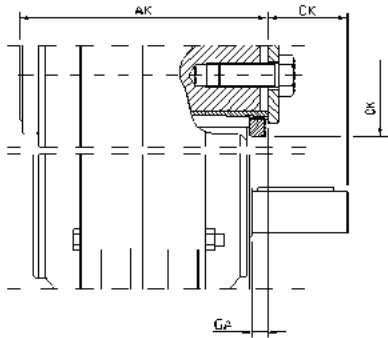
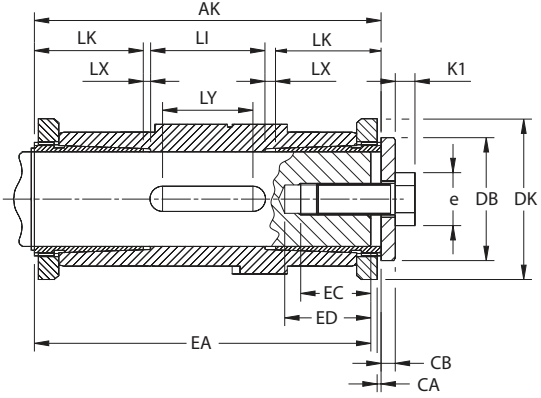
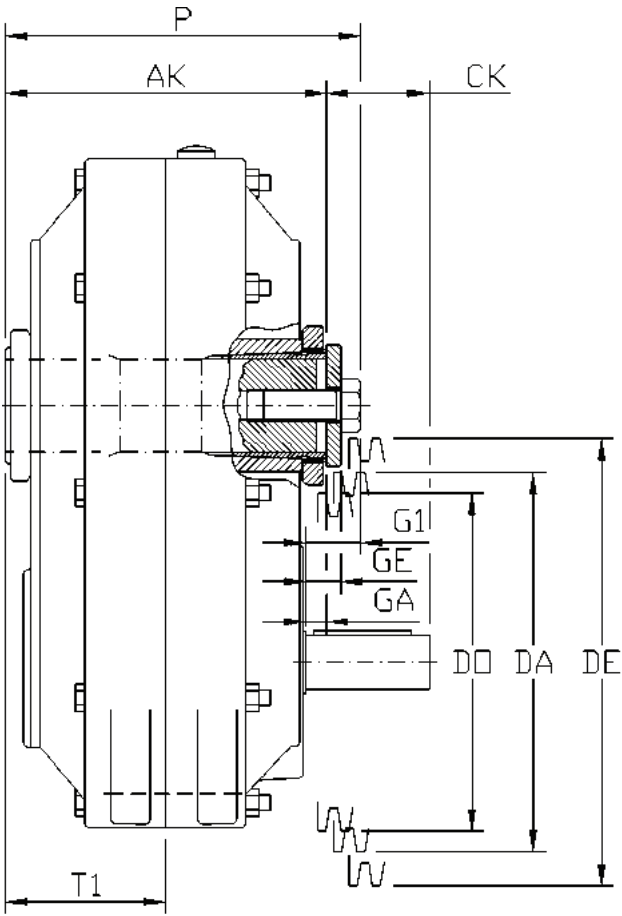

Size	D	Washer		Screw			AK	CA	CK	Max V-belt pulley			DK	EA	EC	ED	G1*	GA*	GE*	LI	LK	LX	LY**	LL	B	P
		DB	CB	M	e	k1				DO	DA	DE														
J12	35	45	10	M12	21.9	8	140	2	36	143	163	186	65	137	28	38	22	4	14	46	40	7	32	54	10	158
J12D45	45	55	12	M16	27.7	10	141	1.5	35.5	133	153	180	75	137	36	45	27	5	17	66	35	2.5	25	71	14	163
J22	45	55	12	M16	27.7	10	161	1.5	45.5	173	193	220	75	157	36	45	27	5	17	56	50	2.5	40	60	14	183
J22D55	55	65	14	M20	34.6	13	168	4	42	163	183	213	85	157	42	53	35	8	22	72	40	8	28	72	16	195
J32	55	65	14	M20	34.6	13	180	4	53.5	207	227	257	85	172	42	53	34	7	21	48	58	8	40	70	16	207
J32D65	65	80	16	M20	34.6	13	184	3	51.5	187	212	257	105	172	42	53	38	9	25	90	43	4	40	80	18	213
J52	60	75	16	M20	34.6	13	202	4	73	256	279	319	98	189	42	53	36	7	23	66	61	7	40	80	18	231
J52D75	75	90	20	M20	34.6	13	206	3	71	234	264	320	120	189	42	53	42	9	29	102	48	4	30	90	20	239
J72	70	85	20	M20	34.6	13	221	3.5	72.5	304	329	379	110	203	42	53	46	13	33	66	67.5	10	56	83	20	254
J72D85	85	100	24	M20	34.6	13	224	3	71	284	314	379	130	203	42	53	51	14	38	104	53	7	45	96	22	261
J100	100	130	7	M24	41.6	15	318	2	154.5	350	375	465	155	296	50	63	13	-14.5	-2	132	83	10	140	89	28	345.5

Dimensions valid for standard ratios.

* Negative value means that the shaft shoulder is located outside.

** Key length

SERIES J

ACCESSORIES - MOTOR MOUNTS

Motor Mounts

The Series J motor mount in combination with a speed reducer gives a compact drive unit. The motor mount is mounted directly on the speed reducer and can be used for all types of foot mounted motors subject to frame size limitation shown below. The V-belt can be tensioned simply by adjusting the torque arm of the motor mount.

Series J motor mounts are economical and eliminate motor alignment.

The motor mounts are available in two performances, one standard and one for heavy duty drives.

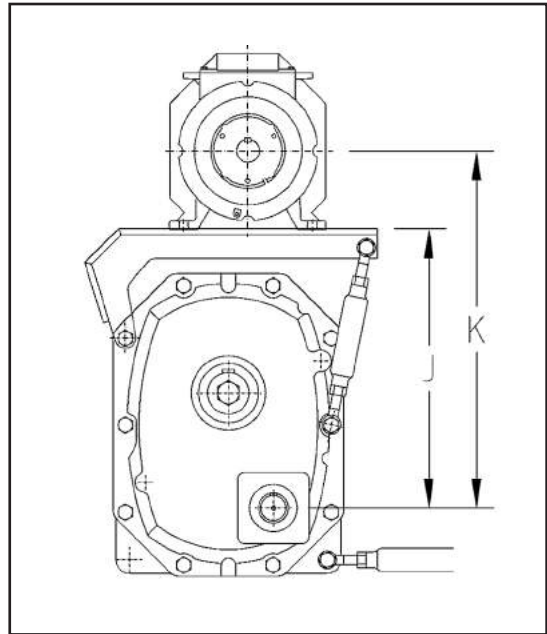

Standard Motor Mount J31 - J72

Mounting Position L

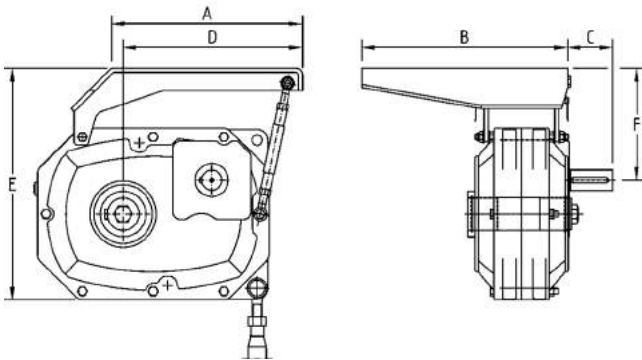

Mounting Position N

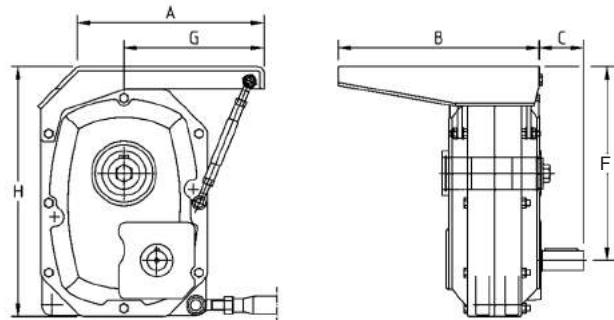

Size	A	B ¹⁾	C	D	E	F	G	H	I	"N"	"L"	K ⁴⁾			kg
										Max belt adjust. ²⁾	IEC c/c motor min/ max	IEC c/c motor min/ max	IEC c/c motor min/ max		
J31	355	385	57	355	385	280	291	411	305	65	70	132-459/524	112-440/505	100-428/493	5
J51	355	385	85	340	422	302	268	477	350	50	65	132-482/532	112-462/512	100-450/500	9
J71	430	370	97	245	452	182	252	583	442	50	65	160-602/652	132-574/624	112-554/604	15
J32	355	385	57	355	385	198	291	411	322	65	70	132-456/521	112-438/503	100-425/490	5
J52	355	385	85	340	422	199	268	477	370	65	70	132-502/565	112-482/547	100-470/535	9
J72	430	370	97	245	452	182	252	583	468	31	100	160-628/631	132-600/631	112-580/611	15

SERIES J

ACCESSORIES - MOTOR MOUNTS

Heavy duty motor mounts (Type T)

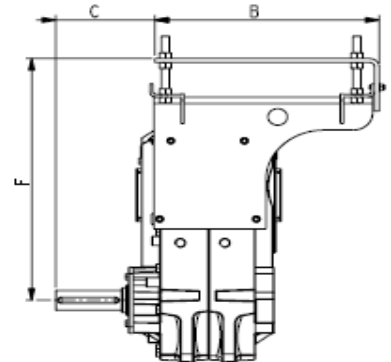
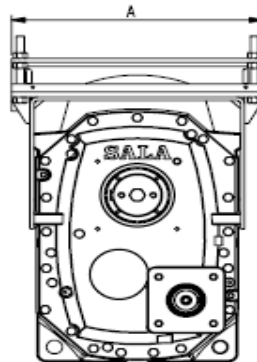
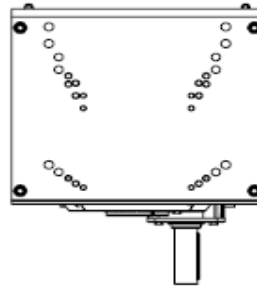
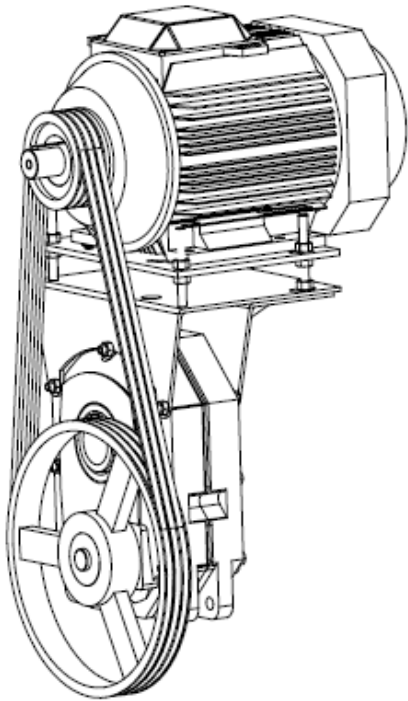

Dimensions in mm

Size	A	B	C	Fmin	Max Belt adjust	kg
J11	300	280	62	268	58	11
J21	356	270	76	290	58	14
J31	426	360	84	348	50	23
J51	476	440	114	415	70	41
J71	506	471	135	473	80	66
J12	300	280	62	285	58	11
J22	356	270	76	310	58	14
J32	426	360	84	365	50	23
J52	476	440	114	435	70	41
J72	506	471	135	500	80	66

Size	A	B	C	Fmin	Max Belt adjust	kg
J100-1step	600	498	190	555	+80	69.7

Size	Motor c/c		
	IEC	min	max
J11	112	380	438
	100	368	426
	90	358	416
J21	132	422	480
	112	402	460
	100	390	448
J31	160	508	558
	132	480	530
	112	460	510
	100	448	498
J51	160	575	645
	132	547	617
	112	527	597
J71	180	653	733
	160	633	713
	132	605	685
	112	585	665
J100-1step	250	805	855
	225	780	860
	200	755	835
	180	735	815
	160	715	795

Size	Motor c/c		
	IEC	min	max
J12	112	397	455
	100	385	443
	90	375	433
J22	132	442	500
	112	422	480
	100	410	468
J32	160	525	575
	132	497	547
	112	477	527
	100	465	515
J52	160	595	665
	132	567	637
	112	547	617
J72	180	680	760
	160	660	740
	132	632	712
	112	612	692
J100-2step	250	845	925
	225	820	900
	200	795	875
	180	775	855
	160	755	835

SERIES J

ACCESSORIES - SHRINK DISC, PROTECTION COVER, BELT PROTECTION

Shrink discs

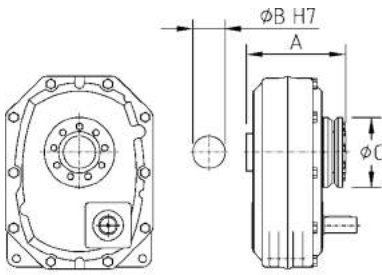

ST - Column 9 entry

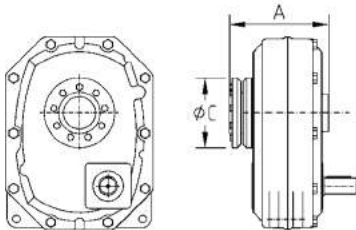

STX - Column 9 entry



Size	Shrink-Disc	A	øB	øC	Max torque (Nm)
J12-ST(X)	3071-44	168	35	80	780
J12D45-ST(X)	3071-55	173	45	100	1520
J22-ST(X)	3071-55	193	45	100	1520
J22D55-ST(X)	3071-68	193	55	115	2500
J32-ST(X)	3071-68	208	55	115	2500
J32D65-ST(X)	3071-75	210	65	138	3950
J52-ST(X)	3071-75	229	60	138	3200
J52D75-ST(X)	3071-90	236	75	155	7250
J72-ST(X)	3071-90	250	70	155	6000
J72D85-ST(X)	3071-110	261	85	185	10800
J100-ST(X)	3171-135	348	100	230	20800

Shrink discs (ST)

Normal tolerance on machine shaft with yield point of appr. 300 N/mm² is h6 up to Ø160, at diameters over Ø160 g6 is required. Required surface finish of shaft is Rt < 16 microns. Transmitted torque will be influenced due to coefficient of friction and choice of correct tolerance as described above. It is also possible to place a shrink disc connection on the other side of the unit (STX). Please consult us or your distributor.

Protection cover - SC

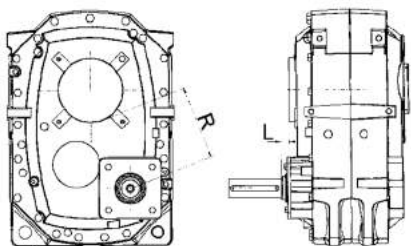

Size	R	L
J100 KIBO 1-step	95	-49

Size	R	L
J100 KIBO 2-step	150,9	-23.5

J	R_2step	L	R_1step
11 / 12	60	-33	43
21 / 22	74	-46	54
31 / 32	86	-48	63
51 / 52	108	-48	82
71 / 72	131	-60	98

*Negative dimensions means that the surface of the cover is outside of shaft shoulder.

Belt protection

Gears can easily be equipped with Belt protection from factory.

Beneficial for the user to get the whole unit as one item, Gear, Motor mount, V-belts, Pulleys, Motor and Belt protection in the same delivery.

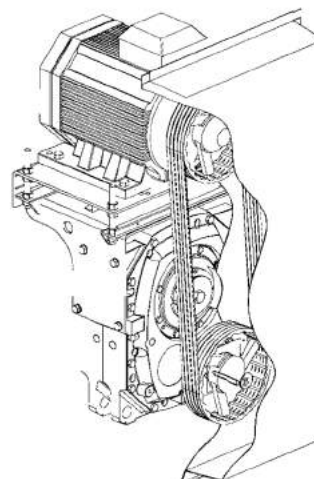

SERIES J

ASSEMBLY OF BACKSTOPS

Mounting of backstop

When using backstops in shaftmounted speed reducers you have to consider among other things the limit of speed and torque according to the following table.

Size	Backstop Type	Max input torque Nm	Input speed r/min	
			Min	Max
J 12	ASNU15EP	75	-	2400
J 22	ASNU17EP	112	-	2300
J 32	ASNU20EP	160	-	2100
J 52	ASNU30EP	500	-	1400
J 72	ASNU30EP	750	-	1200
J 100	RSCI40	1600	720	7600

Max input torque at the backstop is valid at 45×10^6 load changes and must never be exceeded.

Direction of rotation for back stop is valid for double reduction gears. Look at reducer from input shaft side and determine direction of rotation of output shaft sleeve, counterclockwise (BV) or clockwise (BH). See Fig 1.

Please state required direction of rotation when ordering back stop reducer

Column 15 & 16 entries

-	-	NO BACKSTOP
B	V	COUNTER CLOCKWISE ROTATION
B	H	CLOCKWISE ROTATION

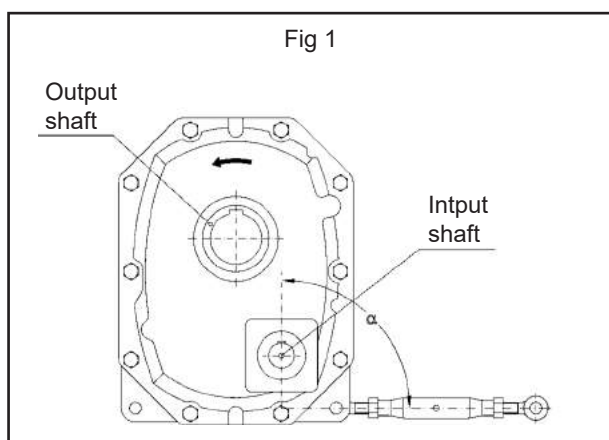

Picture shows counter clockwise rotation (BV)

Tightening torque (29:3)	J12	J22	J32
Nm	17	35	41

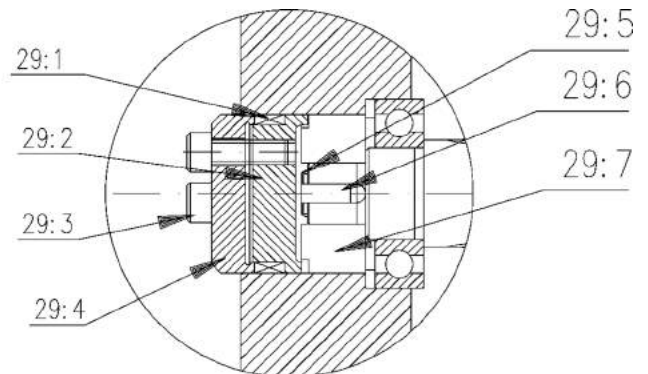

Fig 1

Instruction for backstop J12 - 32.

Assembly see fig 2

Operation temperature $-30\text{ }^{\circ}\text{C}$ to $+100\text{ }^{\circ}\text{C}$.

1. Take out cover (14*) from standard reducer.
2. Fit the key (29:6) into the keyway between shaft (1*) and back stop (29:7).
3. Mount the circlip into groove (29:5).
4. Determine direction of rotation for the back stop (29:7), fit the back stop unit (29:6) into reducer housing push it into close contact with the spacer ring (Direction of rotation is changed if back stop is reversed).
5. Push the backstop bracket (29:2) into the reducer housing and ensure that the two lugs locate with the groove on the back stop.
6. Rub the mechanical joint discs (29:1) with oil.
NOTE: OIL MUST NOT CONTAIN MOLYBDENUMDIFULSIDE
7. Fit the mechanical joint discs (29:1) into backstop bracket (29:2).
8. Apply sealing compound on thread under screw head (29:3) 5 mm width.
9. Fit the cover (29:4) with screws enough to adjust cover. Tighten screws alternating until the required tightening torque is reached.

Dismount see fig 2

1. Dismount the screws (29:3).
2. Dismount the cover (29:4).
3. Dismount the mechanical joint unit by using the three screws (29:3) and tighten the screws against the shaft end / backstop with equal load.
4. Dismount the circlip (29:5).
5. Pull out the backstop (29:7).

*Acc to spare parts list.

SERIES J

ASSEMBLY OF BACKSTOPS

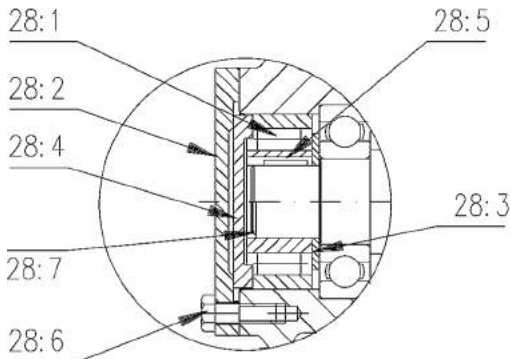

Fig 3

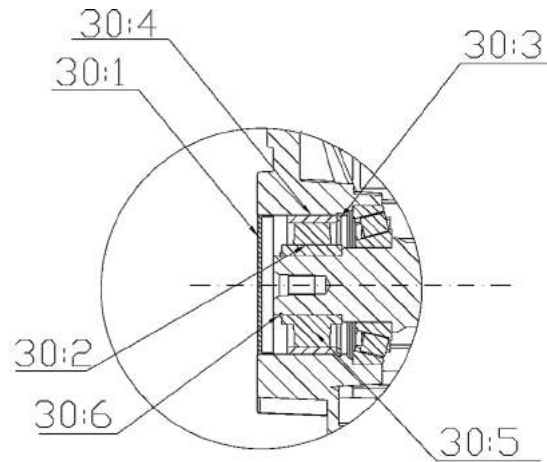

Fig 4

Instruction for backstop J 52 - 72 Assembly see fig 3.

1. Dismantle cover part (14*) from standard reducer.
2. Fit the spacer part (28:3) into the bearing. (Only J52)
3. Grease shaft end where backstop is to be fitted and put key (28:5) into the keyway. For J72 is circlip (28:7) mounted.
4. Determine direction of rotation and fit backstop part (28:1) on to part (1). (Direction of rotation is changed if backstop is reversed.)
5. Fit key (28:4) into key way of cover part (29:3) and screw cover on reducer.

Dismount see fig 3.

1. Dismantle cover part (28:2).
2. Dismantle the key (28:4).
3. Remove circlip from backstop. Fit puller in back stop key way. Turn puller 90 °into circlip groove. Tighten puller screw against shaft end. Dismantle circlip (28:7) for J72.
4. Dismantle the key (28:5) from the shaft end keyway.
5. Dismantle the spacer part (28:3) for J52.

Instruction for backstop J100 Assembly see fig 4.

1. Dismantle the cover part (30:1*) from standard reducer.
2. Assembly the circlip part (30:3*) in gear housing.
3. Grease shaft end where backstop is to be fitted and put Key part (30:2*) into the keyway.
4. Determine direction of rotation and remove outer race part (30:4*) of backstop and fit it gently against the circlip part (30:3*) in gear housing. (Direction of rotation is changed if backstop is reversed).
5. Mount the inner part of backstop, part (30:5*) into guiding ring, (ordered separately).
6. Now press by hand the guiding ring with backstop against the outer race, part (30:4*) and push backstop against shaft shoulder.
7. Remove the guiding ring and fit circlip, part (30:6*) on gear shaft.
8. Fit new cover, part (30:1*), and fill up with oil before starting.

Dismount see fig 4.

1. Dismantle cover, part (30:1*)
2. Remove circlip, part (30:6*)
3. Dismantle circlip from inner race of part (30:5*)
4. Attach a two or three fingered puller in circlip groove of inner race, part (30:5*)
5. Pull out inner race.

Fit new cover, part (30:1*) and fill up with oil before starting.

Operation temperature -30 °C to +100 °C.

*Acc to spare parts list.

MOUNTING INSTRUCTIONS

Mounting Positions

Column 14 Entries

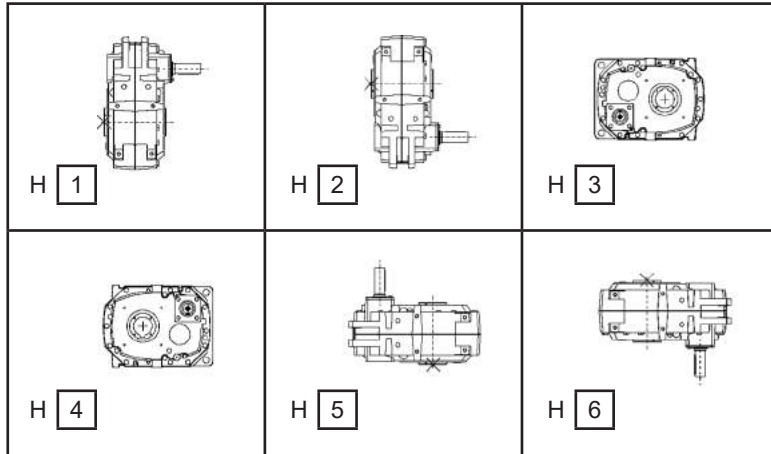

Mounting of speed reducer

1. The reducer should normally be mounted on a shaft with tolerance js6. The hollow shaft has tolerance H7. Lift the reducer in the, for this purpose, suitable hole J11-72 and J100-190 in the torque arm holes or enclosed lifting ears. Grease shaft with Molykote BR2 or corresponding before mounting the speed reducer. The speed reducer must not be forced onto the shaft.
2. When fitting the V-belt pulley use screw to press it into position (tapped hole at input shaft is not standard on type J 11-32). Vbelt pulley must not be forced into position with a hammer as bearings can be damaged. The lock screw for the V-belt pulley should be countersunk into key and locked into position.
3. The torque arm should be positioned so that it is in tension. The direction of rotation of output shaft sleeve, should be determined. In case of counter clockwise rotation. Torque arm should be positioned to the right (see fig 1). For reversible and/ or heavy duty drives, we recommend two torque arms in opposite direction.
4. If back stop is fitted, the direction of rotation of the motor should be checked prior to mounting the V-belt.
5. For applications with heavy duty and/or when speed reducer is mounted in angle of inclination from horizontal machine shaft, locking washer must be used.

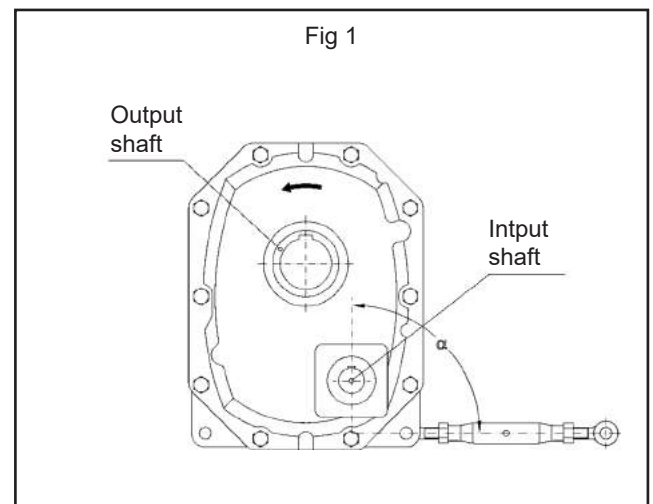

Picture shows counter clockwise rotation

A delivery of a standard Series J shaft mounted speed reducer consists of

For J11-J72

- Torque arm
- Locking bolt, locking pin and washers for the torque arm
- Washer, screw and locking rings (circlips) for the hollow shaft
- Stop screw for the hollow shaft
- Instructions for installation and maintenance and a label saying that no oil is filled.

For J100

- Torque arm
- Locking bolt, locking pin and washers for the torque arm
- Washer, screw and locking rings (circlips) for the hollow shaft
- Stop screws in hollow shaft
- Instructions for installation and maintenance and a label saying that no oil is filled.

LUBRICATION INSTRUCTIONS

The oil filling system of the Series J Speed Reducers means simplified maintenance and oil exchange. Front and back of reducer are equipped with oil level plugs. On the horizontal shaft, oil has to be filled up to suitable plug (see below).

The first oil exchange shall be made after 2500 operating hours. At operation temperatures up to 70°C we recommend oil exchange after 8000 operating hours or every 2 years. At operation temperatures above 70°C oil must be exchanged twice a year. These recommendations apply for operation without shocks. At operation with shocks oil should be exchanged at closer intervals. If J11-100 is in vertical mounting positions please contact our Application Team.

At applications above or below recommended speed please contact our Application Team for recommendation.

Lubrication

Series J units are normally delivered without oil. Different mounting positions require different oil volumes.

Recommended oil in accordance with viscosity grade ISO VG:

Lubricant	Ambient temperature range		
	5°C - 20°C (E) -30°C - 20°C (H)	0°C - 35°C	20°C - 50°C
EP Mineral oil (type E)	5E (VG 220)	6E (VG 320)	7E (VG 460)
Polyalphaolefin based synthetic (type H)	5H (VG 220)	5H (VG 220)	6H (VG 320)

For other ambient temperatures - please consult our Application Engineers.

Quantity of oil and oil level plugs

The figures in the first column under each respective mounting position, shown in the table, refer to the approximate quantities of oil for gear units mounted according to these positions.

If it is required to mount a gear unit in any other position, our Application Engineers should first be consulted. The figures in brackets refer to the numbers of the oil plug which are to function as a level plug.

Approximate quantity of oil in litres

(Ref. number of oil level plug)

J	H1	H2	H3	H4	H5	H6
11A / 11B	0.9 (10)	0.8 (10)	0.9 (3)	0.4 (3)	0.3*	1.5*
21A / 21B	1.1 (10)	1.3 (10)	1.0 (3)	0.3 (3)	0.6*	2.3*
31A / 31B	2.4 (10)	2.1 (10)	2.2 (3)	1.1 (3)	1.6*	3.9*
51A / 51B	4.3 (5)	3.5 (9)	3.9 (3)	1.9 (3)	2.2*	6.3*
71A / 71B	5.9 (6)	5.3 (5)	5.4 (12)	2.5 (11)	2.8*	8.6*
12A / 12B	1.0 (10)	0.4 (10)	0.8 (3)	0.4 (3)	1.2*	1.3*
22A / 22B	1.6 (10)	0.6 (10)	1.4 (3)	0.6 (3)	1.9*	2.1*
32A / 32B	2.4 (10)	1.1 (10)	1.0 (3)	0.9 (3)	3.1*	3.4*
52A / 52B	4.5 (5)	1.6 (9)	3.7 (3)	1.9 (3)	4.8*	5.6*
72A / 72B	5.7 (6)	2.4 (5)	5.1 (12)	2.4 (11)	7.5*	8.3*
100 1-step	11 (6)	11.5 (4)	9 (3)	3 (10)	14 (13)	16 (13)
100 2-step (>50rpm)	10 (6)	4.5 (2)	8 (3)	3 (10)	12.5 (14)	14.5 (13)
100 2-step (<50rpm)		9 (4)				

*Oil level pipe

Output speeds under 15 rpm.

At output speeds below 15 rpm it is very important that all bearings get lubrication. To ensure this it could be necessary to use an oil level pipe. For example sizes J100 in mounting position H2 should be equipped with an oil level pipe.

Note

Lubricants of mineral type should not be mixed with those of synthetic type. Check oil level before new oil is filled.

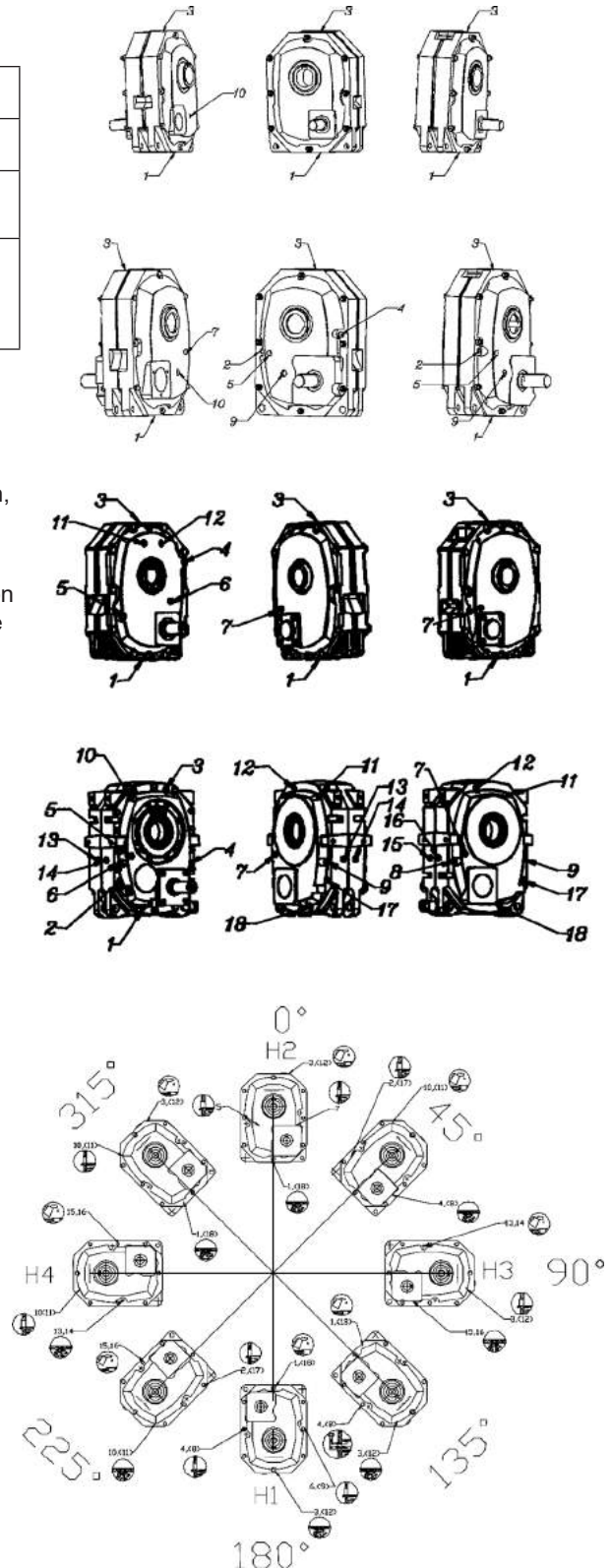

IMPORTANT

Product Safety Information

General - The following information is important in ensuring safety. It must be brought to the attention of personnel involved in the selection of power transmission equipment, those responsible for the design of the machinery in which it is to be incorporated and those involved in its installation, use and maintenance.

Our equipment will operate safely provided it is selected, installed, used and maintained properly. As with any power transmission equipment proper precautions must be taken as indicated in the following paragraphs, to ensure safety.

Potential Hazards - these are not necessarily listed in any order of severity as the degree of danger varies in individual circumstances. It is important therefore that the list is studied in its entirety:-

- 1) Fire/Explosion
 - (a) Oil mists and vapour are generated within gear units. It is therefore dangerous to use naked lights in the proximity of gearbox openings, due to the risk of fire or explosion.
 - (b) In the event of fire or serious overheating (over 300 oC), certain materials (rubber, plastics, etc.) may decompose and produce fumes. Care should be taken to avoid exposure to the fumes, and the remains of burned or overheated plastic/rubber materials should be handled with rubber gloves.
- 2) Guards - Rotating shafts and couplings must be guarded to eliminate the possibility of physical contact or entanglement of clothing. It should be of rigid construction and firmly secured.
- 3) Noise - High speed gearboxes and gearbox driven machinery may produce noise levels which are damaging to the hearing with prolonged exposure. Ear defenders should be provided for personnel in these circumstances. Reference should be made to the Department of Employment Code of Practice for reducing exposure of employed persons to noise.
- 4) Lifting - Where provided (on larger units) only the lifting points or eyebolts must be used for lifting operations (see maintenance manual or general arrangement drawing for lifting point positions). Failure to use the lifting points provided may result in personal injury and/or damage to the product or surrounding equipment. Keep clear of raised equipment.
- 5) Lubricants and Lubrication
 - (a) Prolonged contact with lubricants can be detrimental to the skin. The manufacturer's instruction must be followed when handling lubricants.
 - (b) The lubrication status of the equipment must be checked before commissioning. Read and carry out all instructions on the lubricant plate and in the installation and maintenance literature. Heed all warning tags. Failure to do so could result in mechanical damage and in extreme cases risk of injury to personnel.
- 6) Electrical Equipment - Observe hazard warnings on electrical equipment and isolate power before working on the gearbox or associated equipment, in order to prevent the machinery being started.
- 7) Installation, Maintenance and Storage
 - (a) In the event that equipment is to be held in storage, for a period exceeding 6 months, prior to installation or commissioning, we must be consulted regarding special preservation requirements. Unless otherwise agreed, equipment must be stored in a building protected from extremes of temperature and humidity to prevent deterioration.
The rotating components (gears and shafts) must be turned a few revolutions once a month (to prevent bearings brinelling).
 - (b) External gearbox components may be supplied with preservative materials applied, in the form of a "waxed" tape overwrap or wax film preservative. Gloves should be worn when removing these materials. The former can be removed manually, the latter using white spirit as a solvent.
Preservatives applied to the internal parts of the gear units do not require removal prior to operation.
 - (c) Installation must be performed in accordance with the manufacturer's instructions and be undertaken by suitably qualified personnel.
 - (d) Before working on a gearbox or associated equipment, ensure that the load has been removed from the system to eliminate the possibility of any movement of the machinery and isolate power supply. Where necessary, provide mechanical means to ensure the machinery cannot move or rotate. Ensure removal of such devices after work is complete.
 - (e) Ensure the proper maintenance of gearboxes in operation. Use only the correct tools and our approved spare parts for repair and maintenance. Consult the Maintenance Manual before dismantling or performing maintenance work.
- 8) Hot Surfaces and Lubricants
 - (a) During operation, gear units may become sufficiently hot to cause skin burns. Care must be taken to avoid accidental contact.
 - (b) After extended running the lubricant in gear units and lubrication systems may reach temperatures sufficient to cause burns. Allow equipment to cool before servicing or performing adjustments.
- 9) Selection and Design
 - (a) Where gear units provide a backstop facility, ensure that back-up systems are provided if failure of the backstop device would endanger personnel or result in damage.
 - (b) The driving and driven equipment must be correctly selected to ensure that the complete machinery installation will perform satisfactorily, avoiding system critical speeds, system torsional vibration, etc.
 - (c) The equipment must not be operated in an environment or at speeds, powers, torques or with external loads beyond those for which it was designed.
 - (d) As improvements in design are being made continually the contents of this catalogue are not to be regarded as binding in detail, and drawings and capacities are subject to alterations without notice.

The above guidance is based on the current state of knowledge and our best assessment of the potential hazards in the operation of the gear units.

Any further information or clarification required may be obtained by contacting our Application Engineers.



MARKETING & SERVICING COMPANY



EMTICI ENGINEERING LIMITED

REGISTERED OFFICE :

Anand - Sojitra Road, Vallabh Vidyanagar - 388 120. Gujarat, INDIA.
Phones : +91 269 223 0168, +91 269 223 1125 Fax : +91 269 223 6508
Website : www.emtici.co.in

: BRANCH OFFICES :

Ahmedabad:

Phone: +91 79 26406683,
26406684, 26406685
Fax : +91 79 26401363
Email : sales@ahdemtici.elecon.com

Bangalore:

Phone: +91 80 25250219,
25290082, 25252925
Fax : +91 80 25251834
Email : salesbgl@emtici.co.in

Chennai:

Phone: +91 44 24349237,
24349497, 24322455
Fax : +91 44 24349643
Email : salesmad@emtici.co.in

Dhanbad:

Phone: +91 326 2230404
Fax : +91 326 2230490
Email : slahiri@emtici.co.in

Indore:

Phone: +91 731 2576100
Fax : +91 731 2558077
Email : deepankar@emtici.co.in

Jamshedpur:

Phone: +91 657 2361837
Fax : +91 657 246424
Email : slahiri@emtici.co.in

Kolkata:

Phone: +91 33 24761, 24760876
Fax : +91 33 24761831
Email : slahiri@emtici.co.in

Madurai:

Phone: +91 4549 293488
Fax : +91 4549 293468
Email : salesmad@emtici.co.in

Mumbai:

Phone: +91 22 22821315
Fax : +91 22 22870791
Email : smkulat@emtici.co.in

Nagpur:

Phone: +91 712 6642616, 6642601
Fax : +91 712 6642622
Email : rbpande@emtici.co.in

New Delhi:

Phone: +91 11 23414340,
23414340, 23414069
Fax : +91 11 23709046
Email : sbhattachary@emtici.co.in

Pune:

Phone: +91 20 40191400
Fax : +91 20 40191420
Email : smkulat@emtici.co.in

Raipur:

Phone: +91 771 4081541,
2259329/324
Fax : +91 771 4081541
Email : pksingh@emtici.co.in

Secunderabad:

Phone: +91 40 27844748
Fax : +91 40 27848317
Email : salesec@emtici.co.in

Vadodara:

Phone: +91 265 2312972, 23136701
Fax : +91 265 2312982
Email : salesbrd@emtici.co.in

Visakhapatnam:

Phone: +91 891 2531630,
+91 891 2731630
Email : salessec@emtici.co.in



SMS NAME, CITY, Assistance Needed

INTERNATIONAL LOCATIONS

UK | SWEDEN | USA | NETHERLANDS | SINGAPORE
GERMANY | FINLAND | DENMARK | AUSTRALIA | ITALY

SUBSIDIARIES

1. RADICON TRANSMISSION THAILAND LTD. (THAILAND)
2. RADICON TRANSMISSION FZE (UAE)

GEARED MOTORS • GEARBOXES • GEAR ASSEMBLIES • DRIVE SOLUTIONS

POWER BUILD PVT LTD
Leaders in Power Transmission Solutions

Anand Sojitra Road, Vallabh Vidyanagar, Anand - 388120 (Gujarat) India Tel.: +91 (2692) 231070, 231120, 231170, Mo.: +91 97277 19344

CIN U32201GJ1972PTC002065